

BROWNING DAY MULLINS DIERDORF ARCHITECTS

Browning Day Mullins Dierdorf Architects
Landscape Architecture
Planning

334 North Senate Avenue
Indianapolis, Indiana 46204
P: 317.835.5030
F: 317.781.8200
E-Mail: jms@bmdm.com

Circle Design Group, Inc.
Mechanical Electrical Plumbing Engineers

5510 South East Street, Suite F
Indianapolis, Indiana 46227
P: 317.781.8200
F: 317.781.8201
E-Mail: kerry@circledesigngroup.com

Lawson Eiser Engineering Consultants
Structural Engineers

650 East Carmel Drive, Suite 150
Carmel, Indiana 46032
P: 317.574.9409
F: 317.574.9451
E-Mail: mlawson@lawsoneiser.com

Skews Engineering, Inc.
Civil Engineers

400 Blankenshaker Parkway, Suite 300
Louisville, KY 40263
P: 502.254.2344
F: 502.254.3008
E-Mail: dmckinnon@skews.com

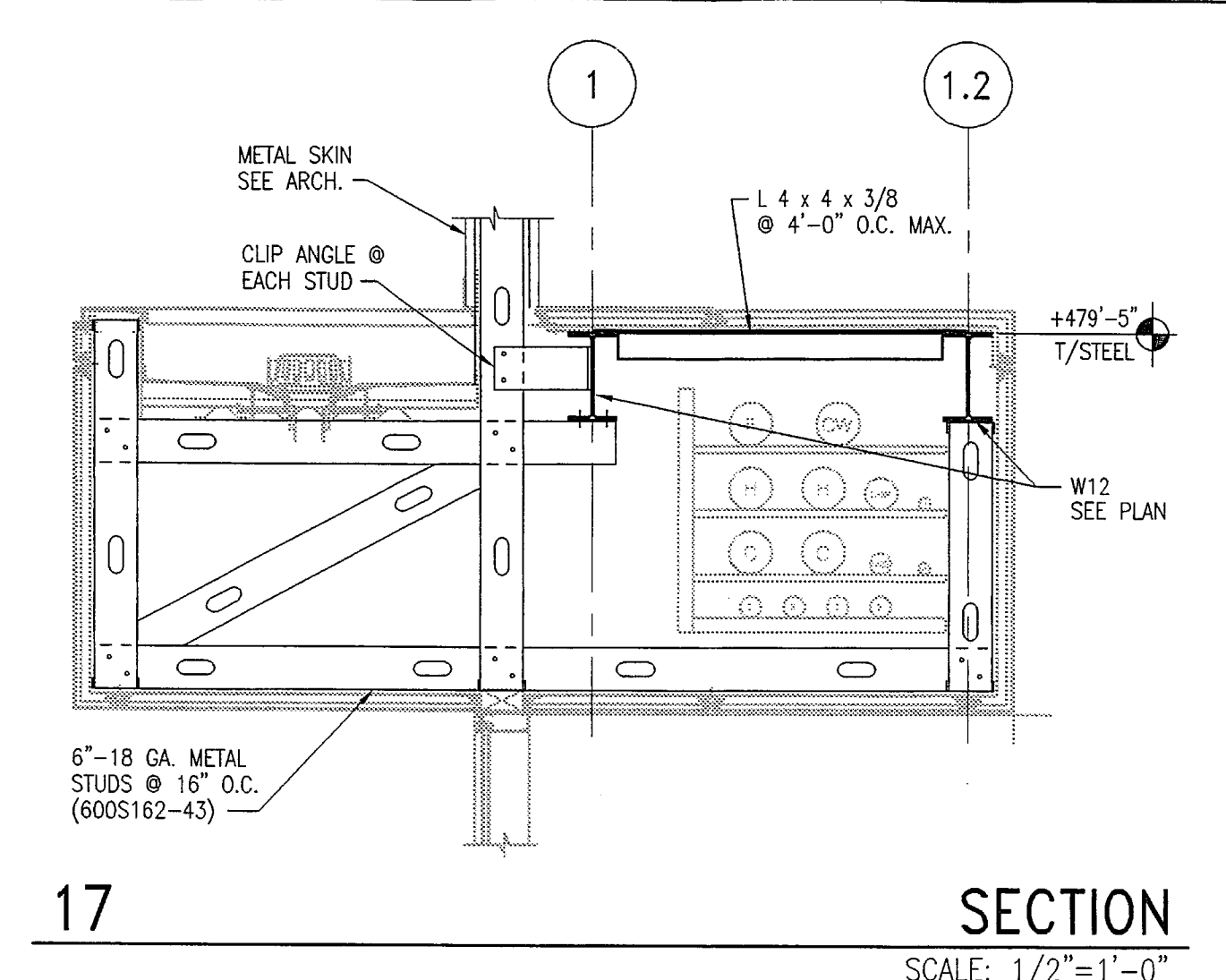

17 SECTION
SCALE: 1/2"=1'-0"

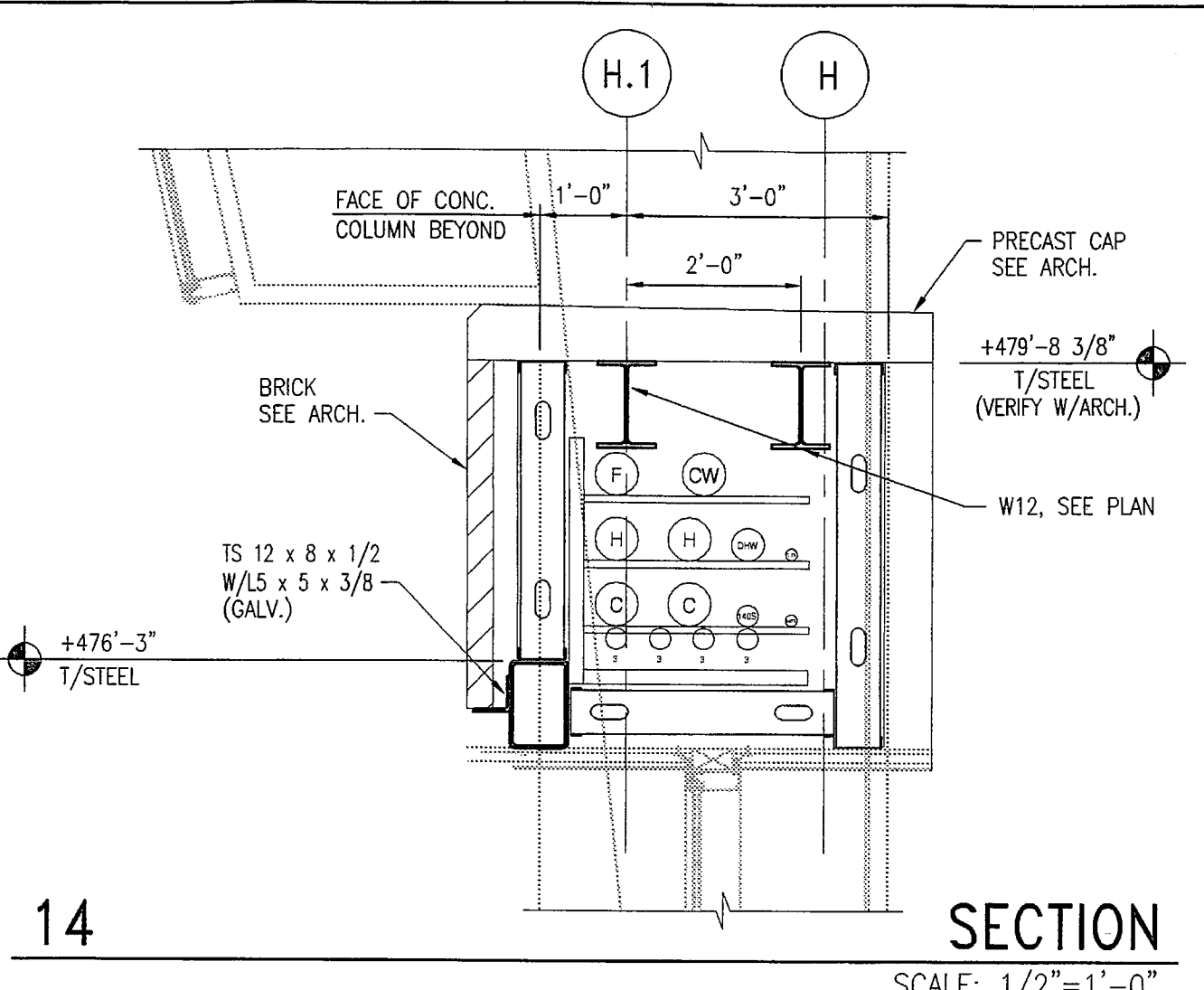

14 SECTION
SCALE: 1/2"=1'-0"

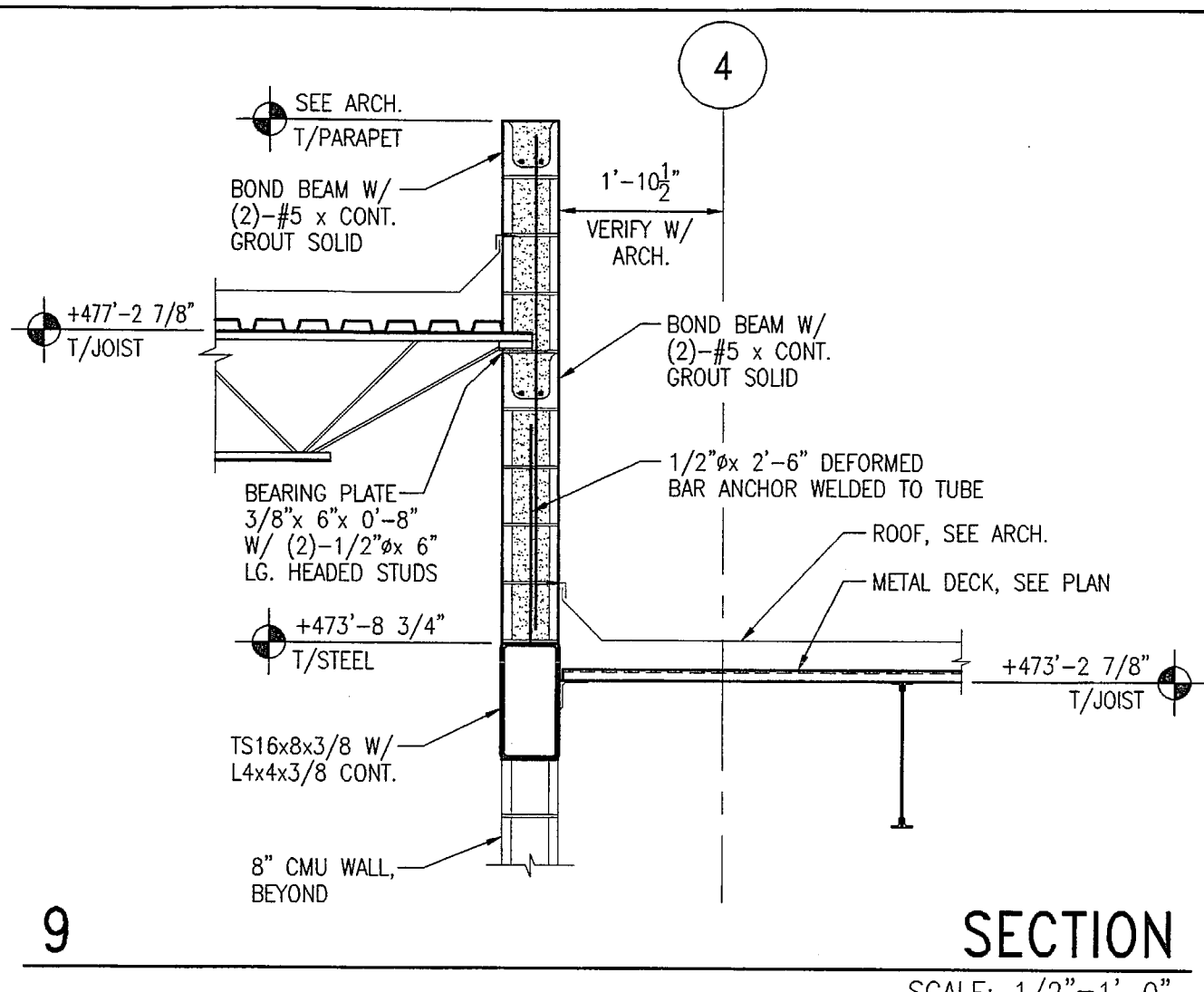

9 SECTION
SCALE: 1/2"=1'-0"

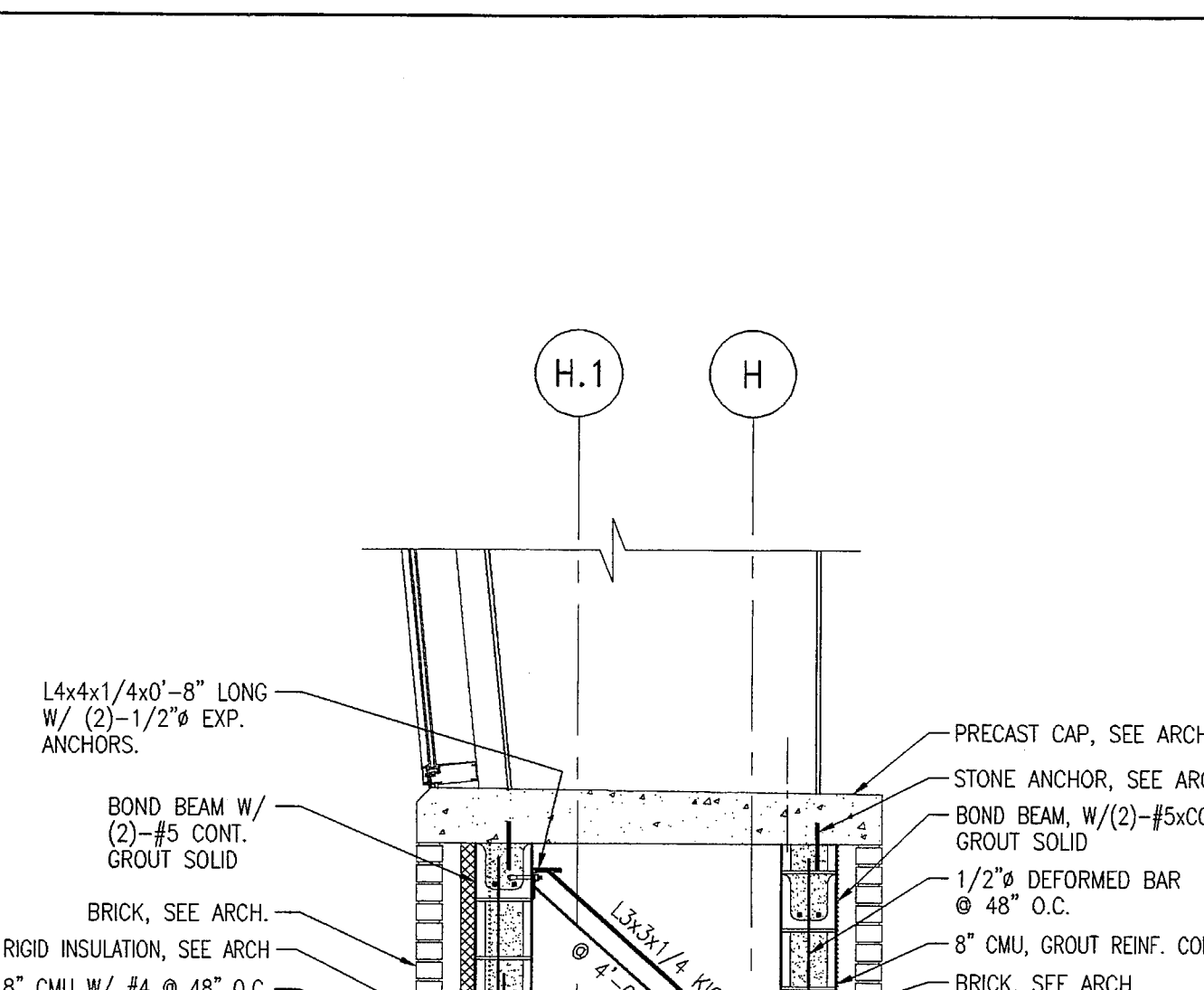

5 SECTION
SCALE: 1/2"=1'-0"

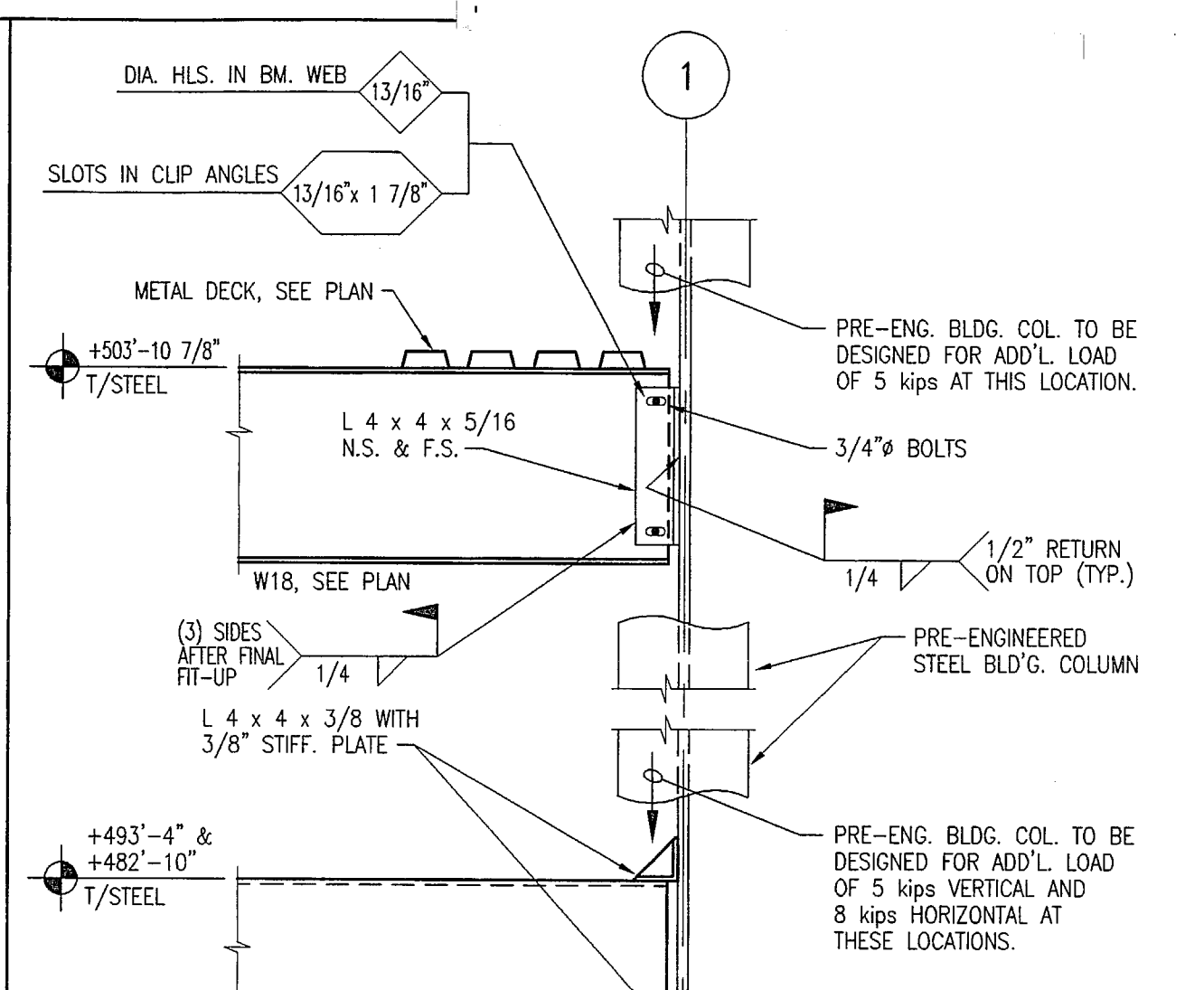

1 SECTION
SCALE: 3/4"=1'-0"

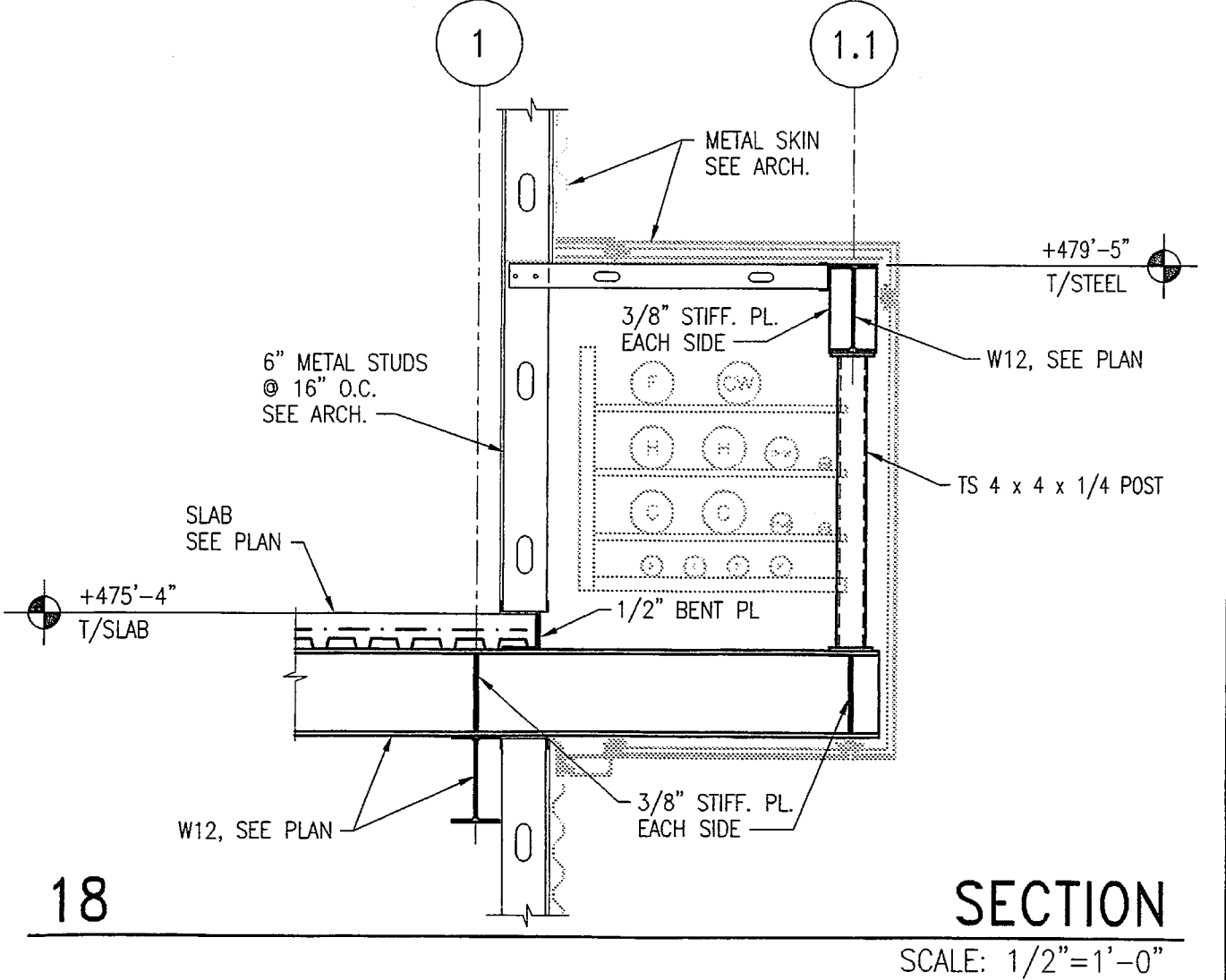

18 SECTION
SCALE: 1/2"=1'-0"

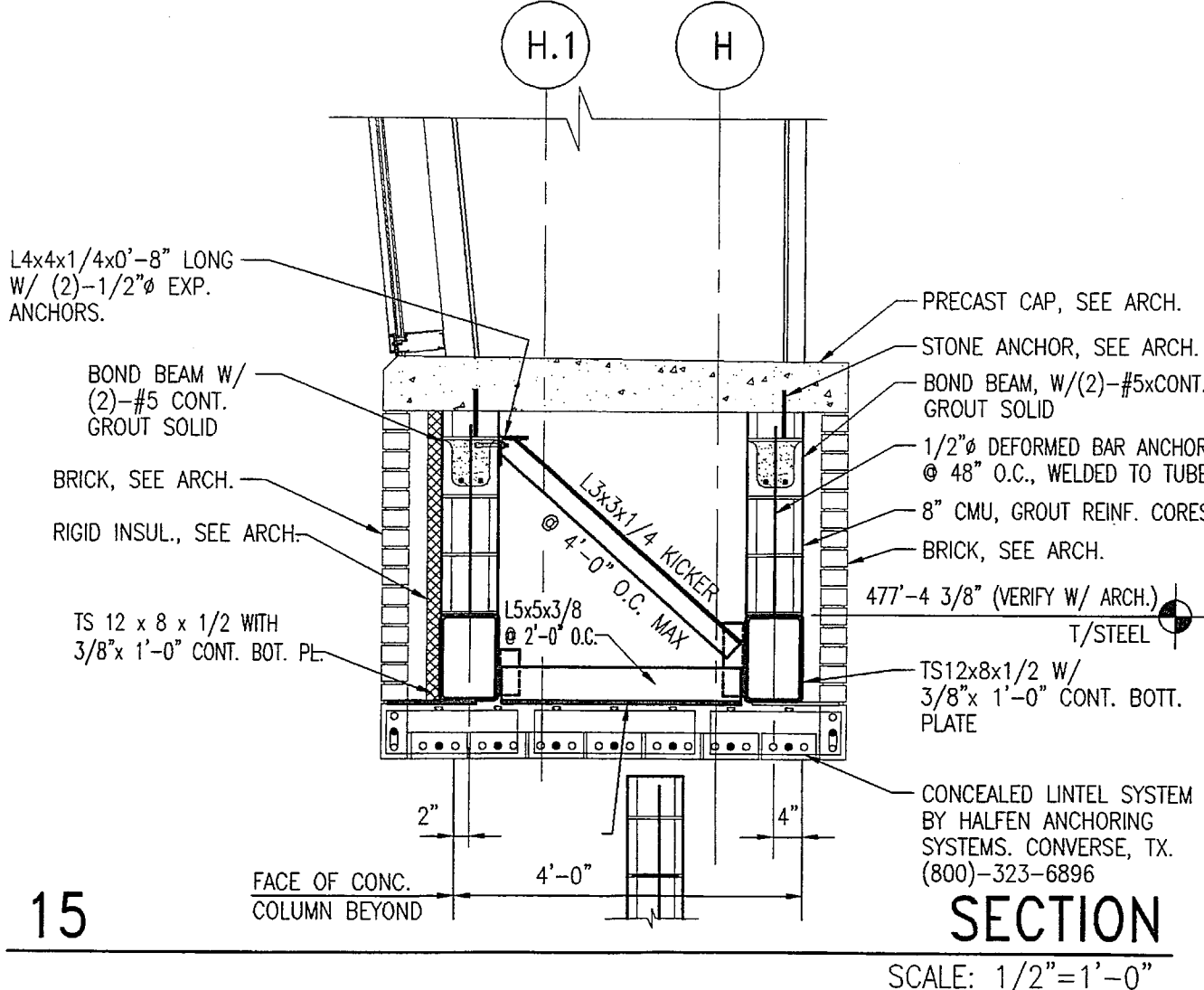

15 SECTION
SCALE: 1/2"=1'-0"

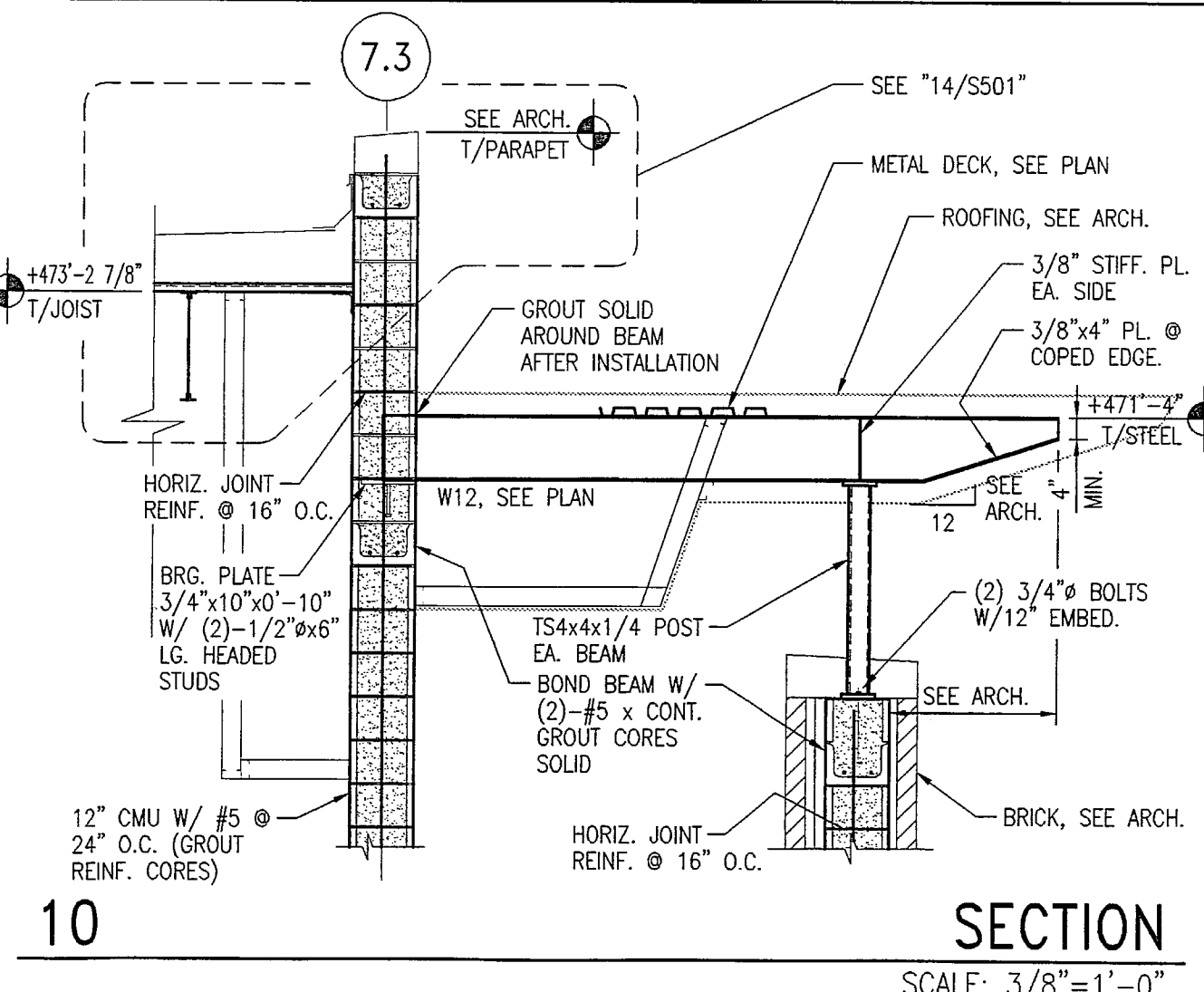

10 SECTION
SCALE: 3/8"=1'-0"

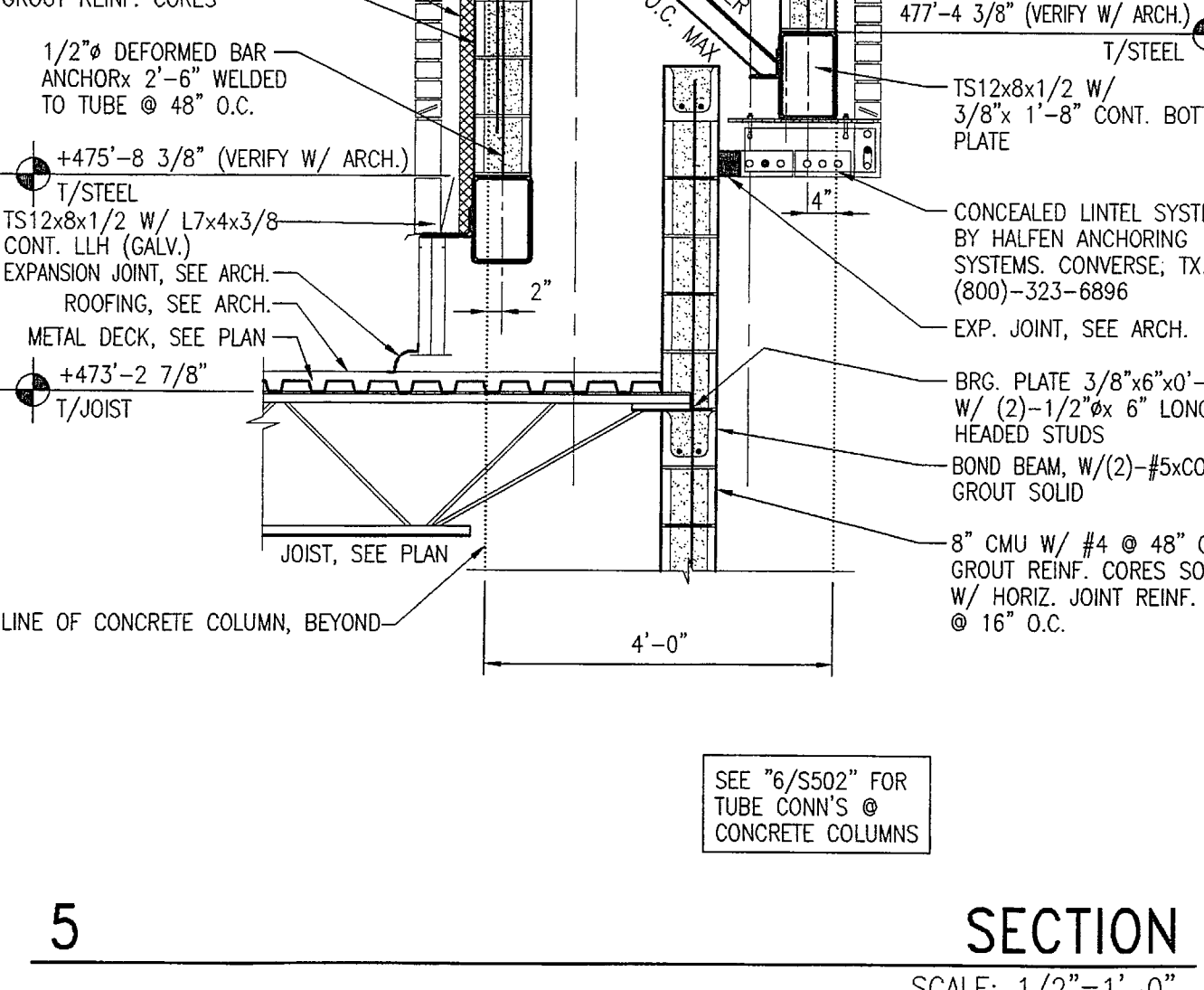

6 SECTION
SCALE: 1/2"=1'-0"

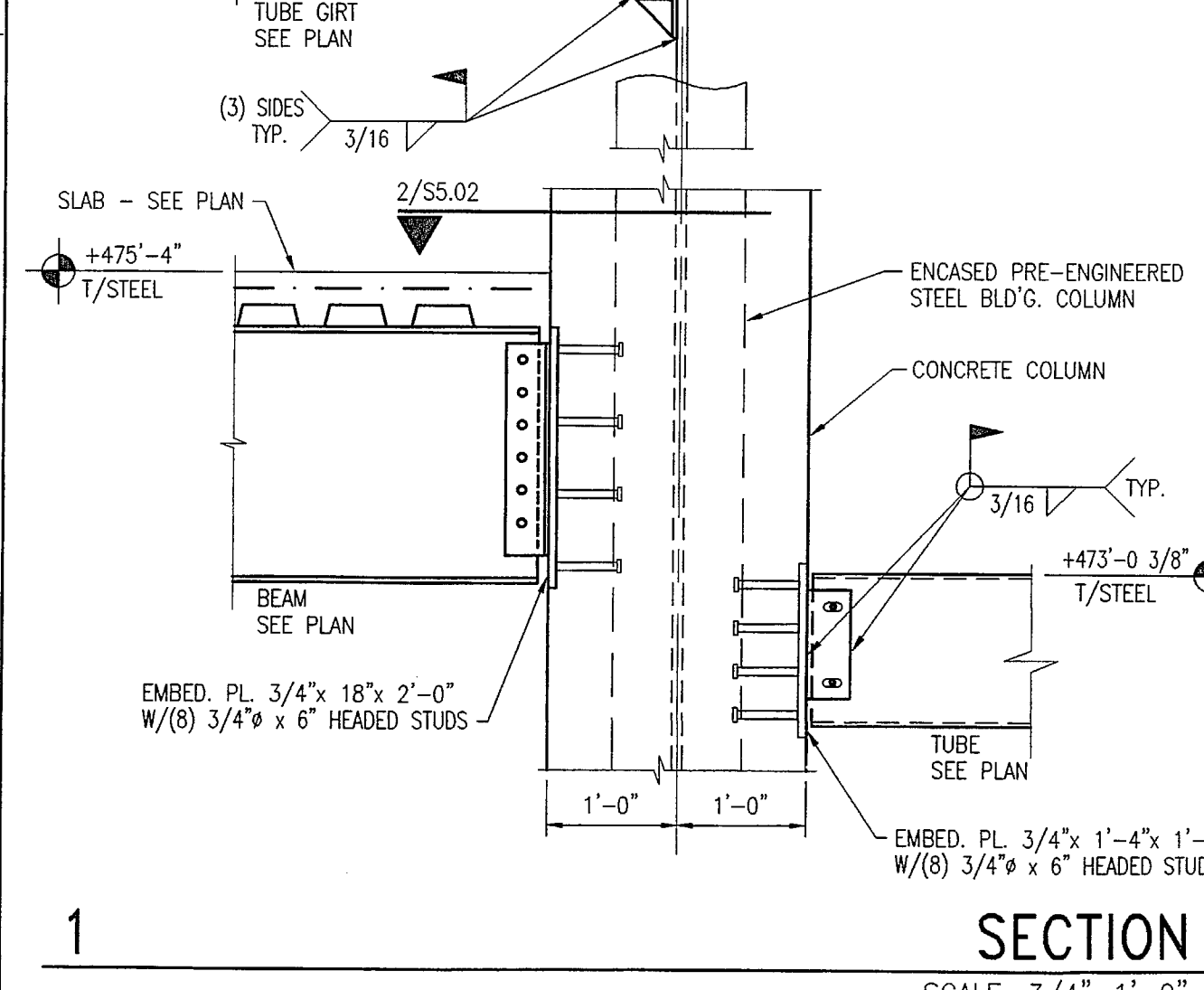

2 SECTION
SCALE: 1"=1'-0"

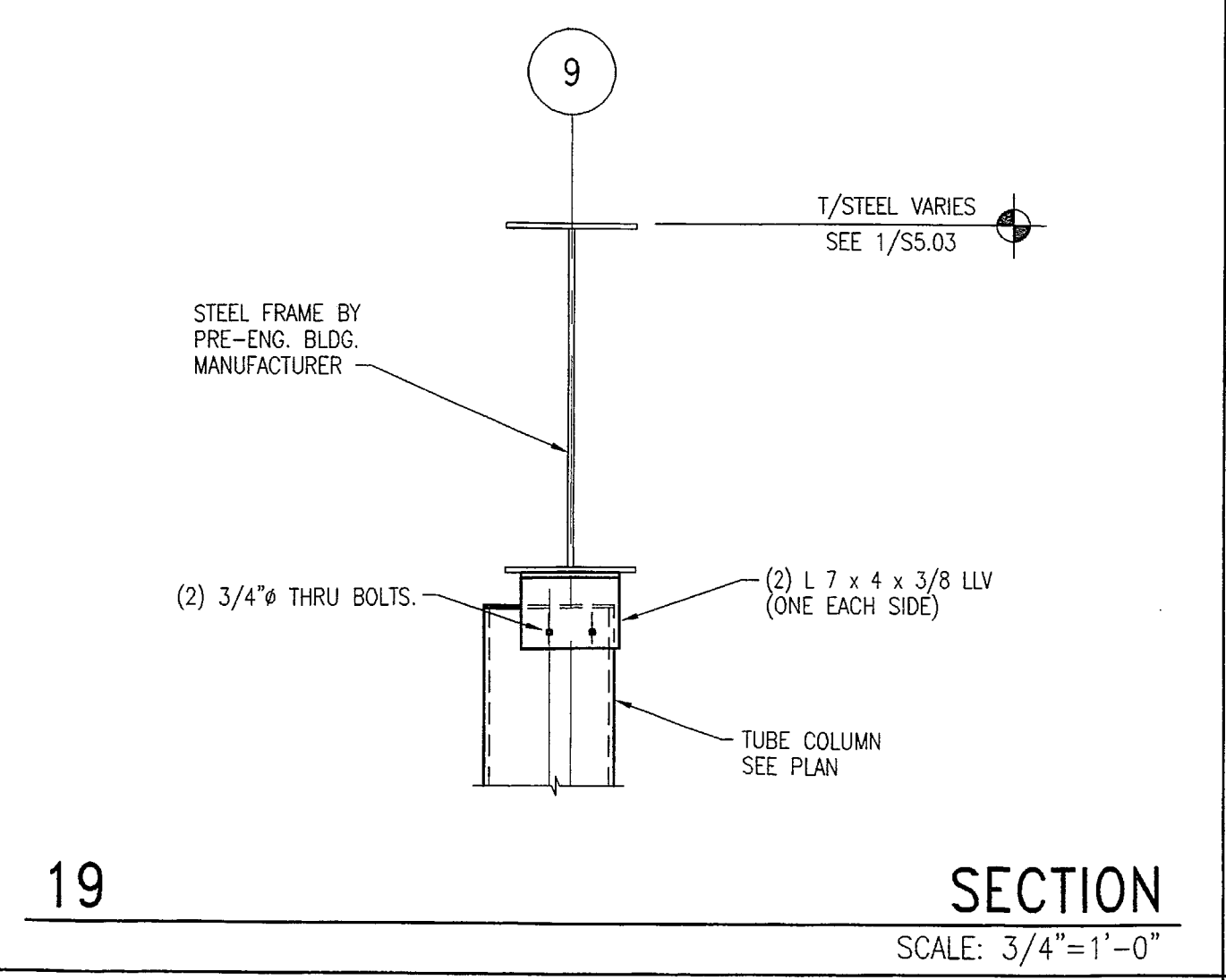

19 SECTION
SCALE: 3/4"=1'-0"

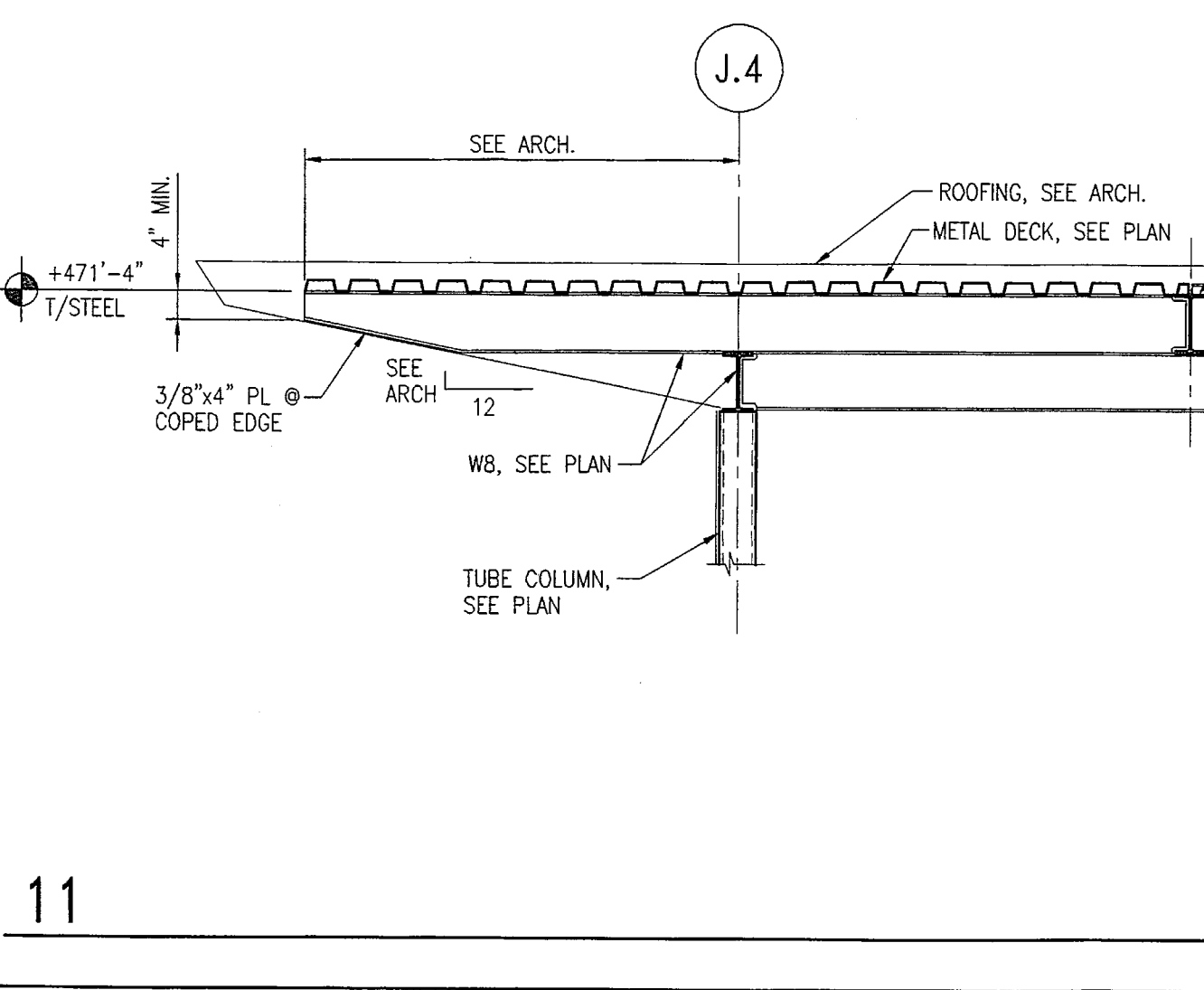

11 SECTION
SCALE: 1/2"=1'-0"

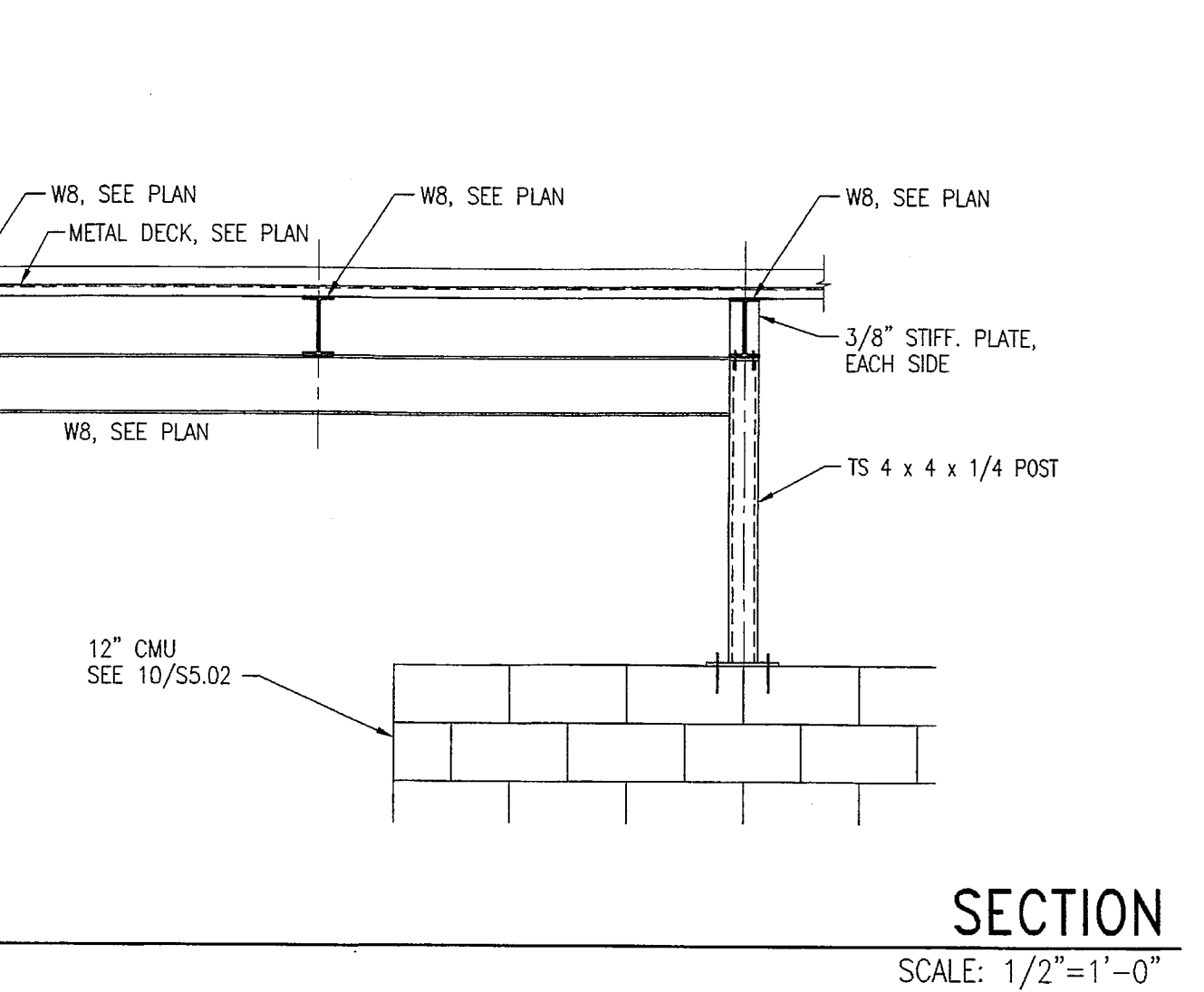

12 SECTION
SCALE: 3/4"=1'-0"

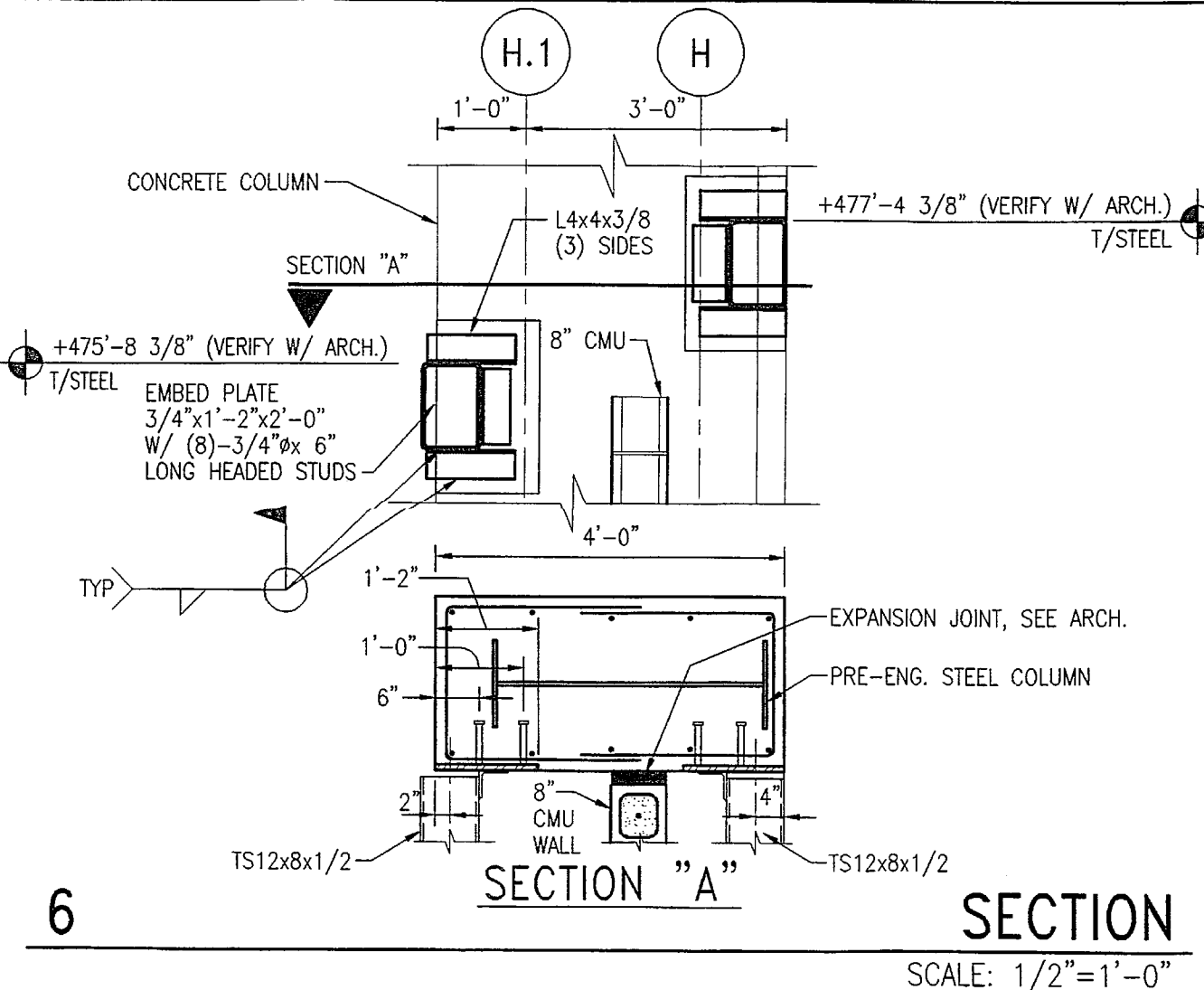

7 SECTION
SCALE: 3/4"=1'-0"

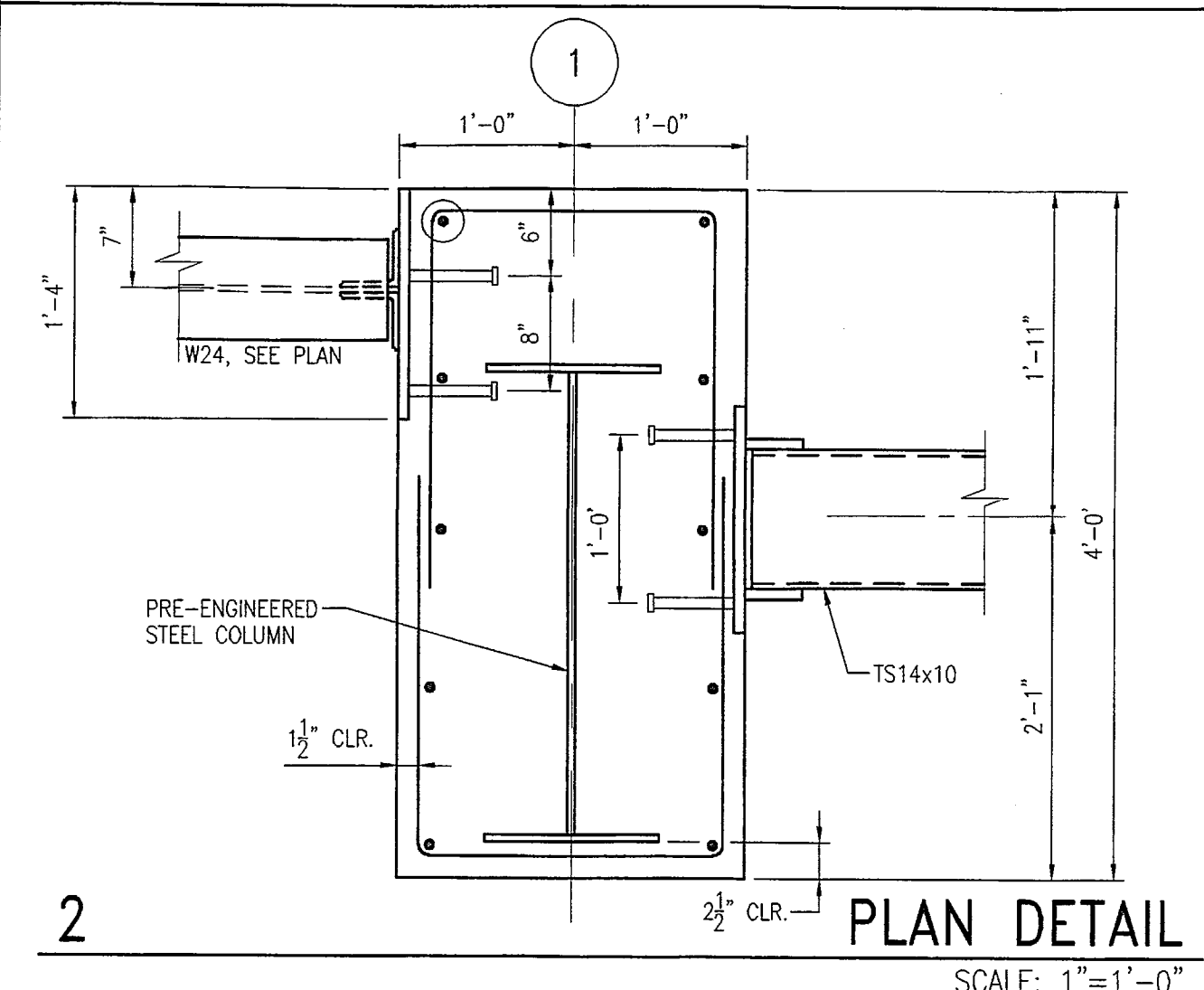

3 SECTION
SCALE: 1/2"=1'-0"

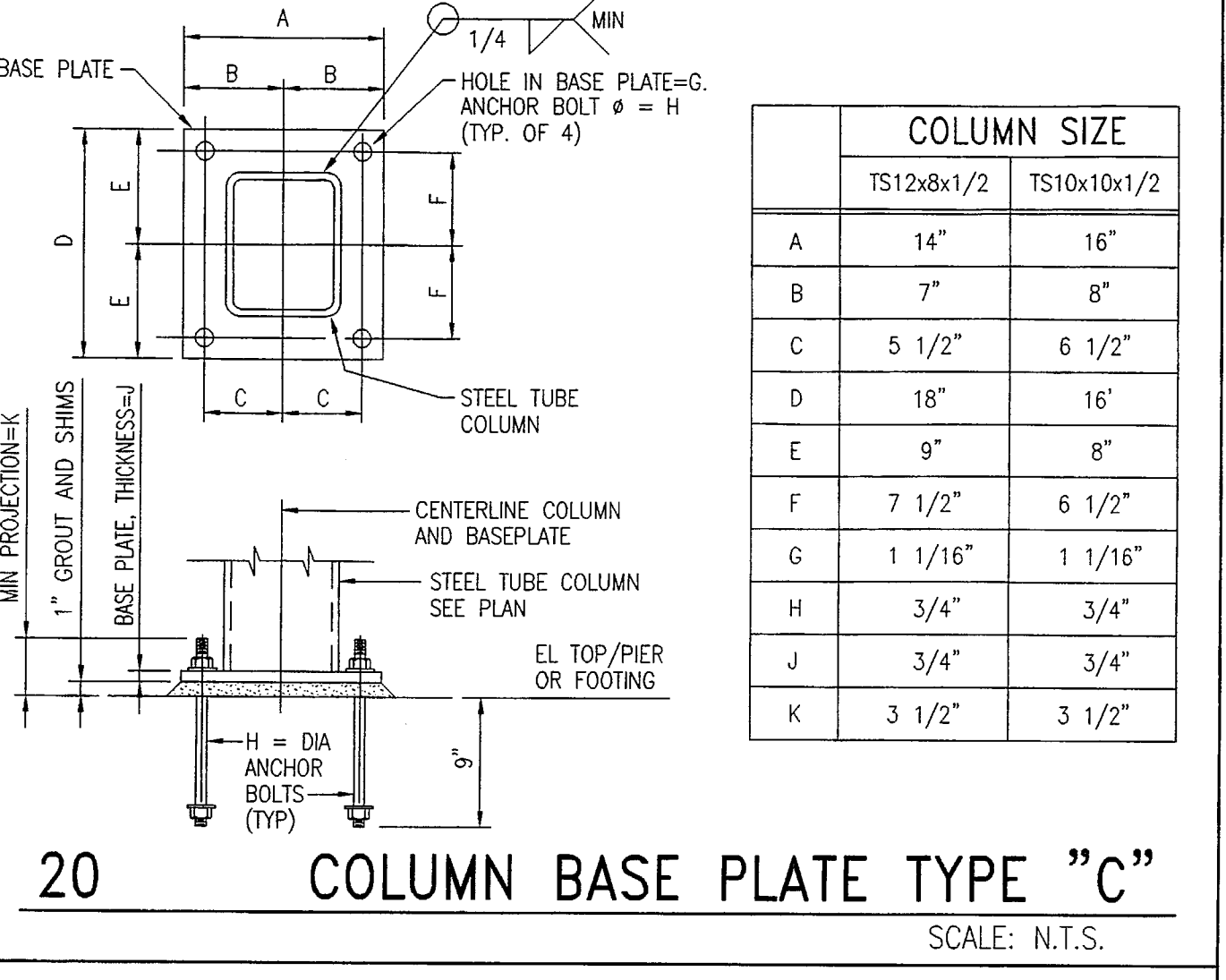

20 COLUMN BASE PLATE TYPE "C"
SCALE: N.T.S.

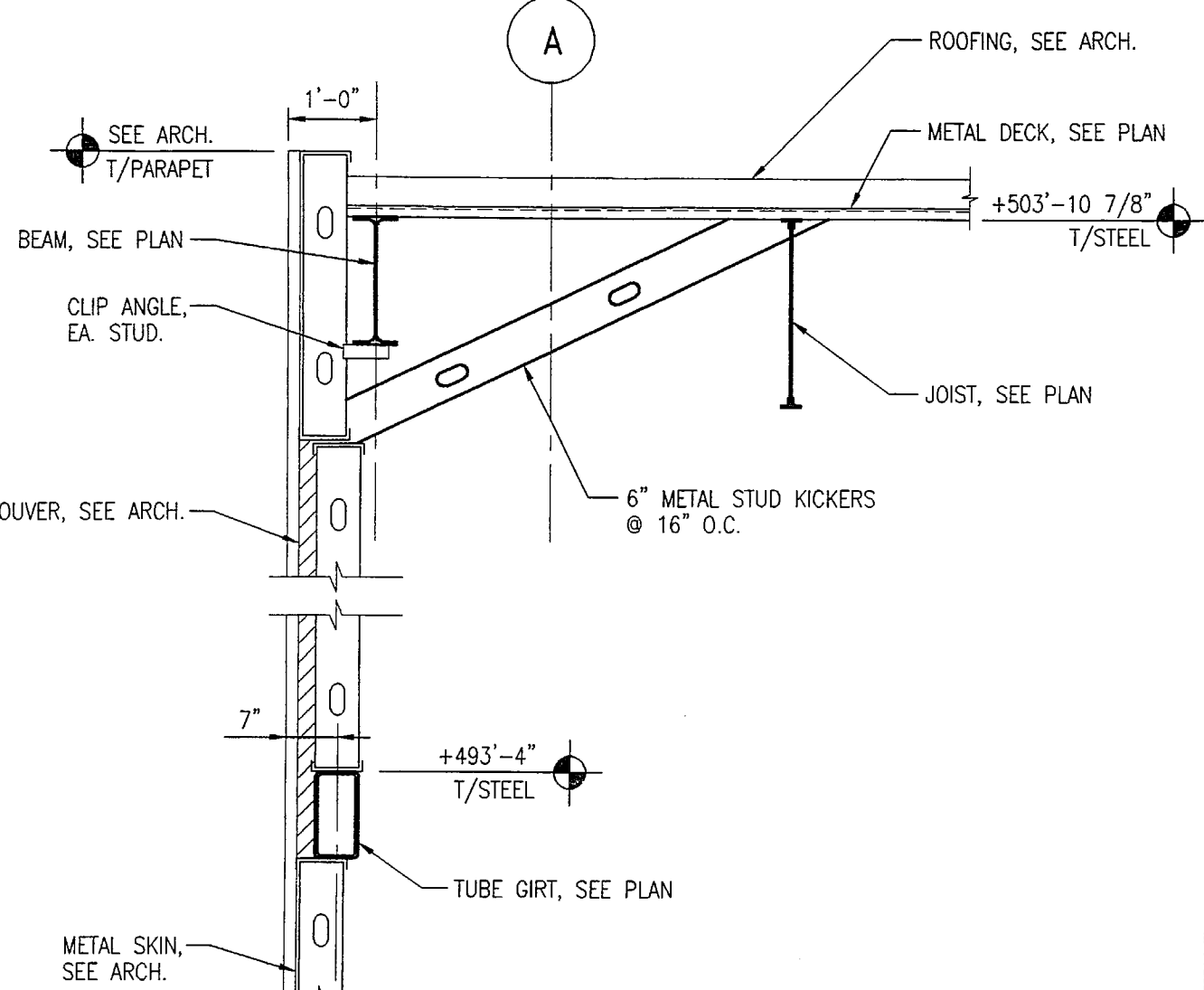

16 SECTION
SCALE: 1/2"=1'-0"

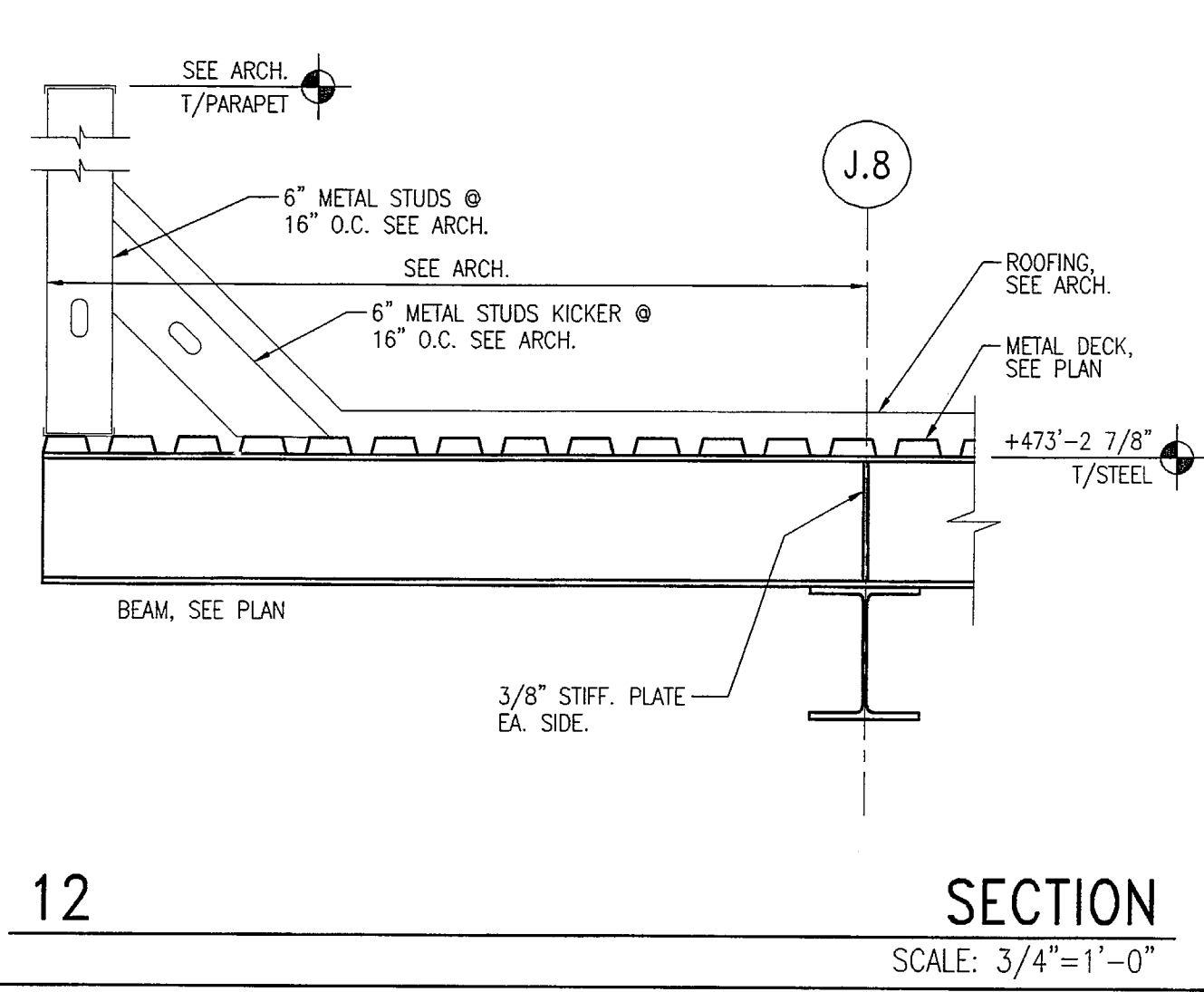

13 SECTION
SCALE: 1/2"=1'-0"

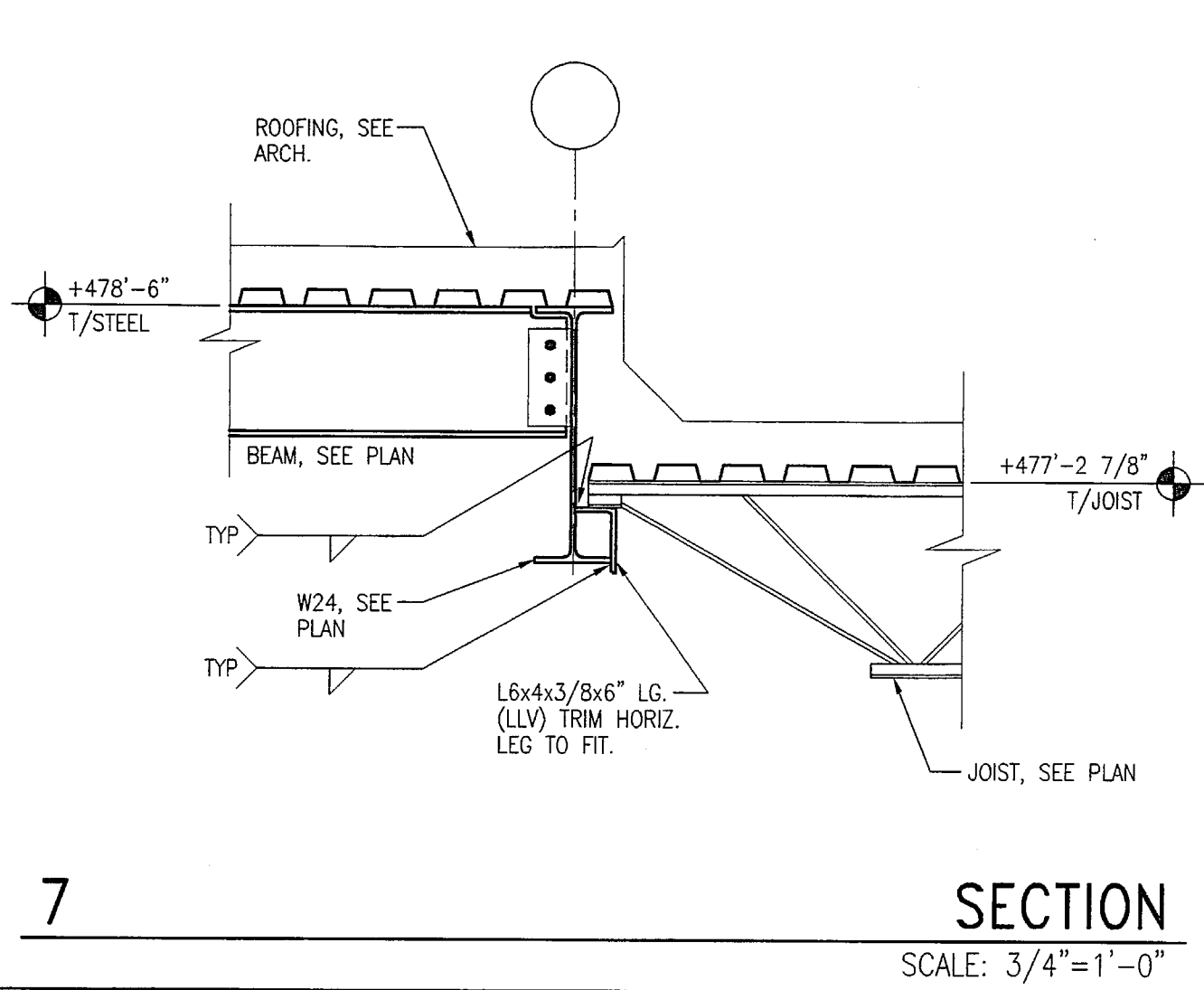

8 SECTION
SCALE: 3/4"=1'-0"

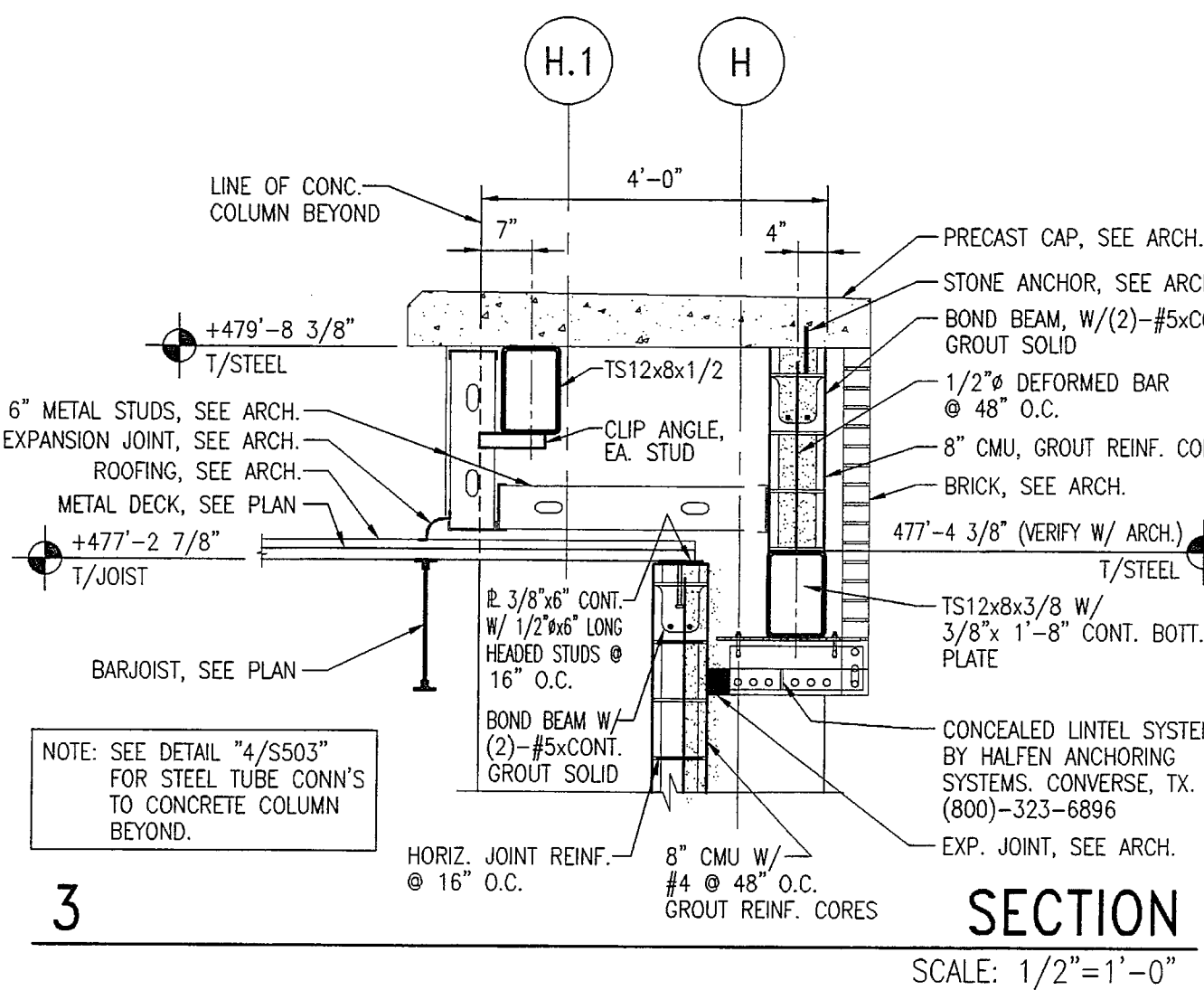

4 SECTION
SCALE: 1/2"=1'-0"

MISCELLANEOUS STEEL LINTEL SCHEDULE			
CLEAR SPAN	WALL TYPE	BRG	SHAPE
2'-4" TO 6'-4"	4" BRICK-12" MAX	4" MIN	1 - L 5 x 3 1/2 x 1/4 (LLV) FOR EACH 4" OF WALL THICKNESS.
6'-4" TO 10'-4"	4" BRICK-12" MAX 8" TO 12" BLOCK 8" BLOCK + 4" BRICK	8" MIN	W8x10 W/ 1/4" PLATE R WIDTH TO BE WALL THICKNESS LESS 1/2".
10'-4" TO 12'-4"	4" BRICK-12" MAX 8" TO 12" BLOCK 8" BLOCK + 4" BRICK	12" MIN	W8x15 W/ 1/4" PLATE R WIDTH TO BE WALL THICKNESS LESS 1/2".

21 LINTEL SCHEDULE
SCALE: N.T.S.

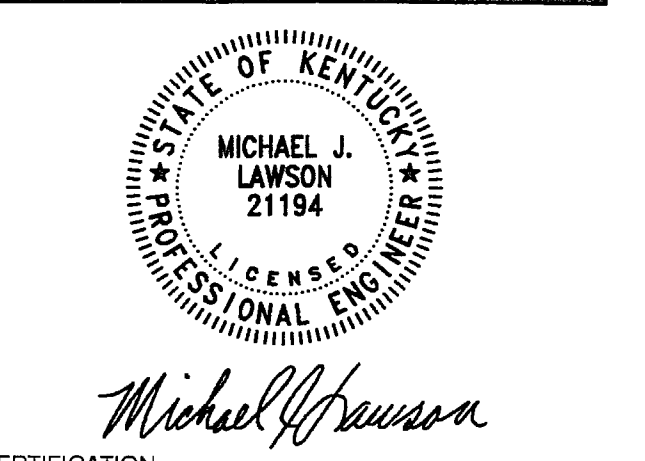

CERTIFICATION
CONSTRUCTION DOCUMENTS

CARDINAL PARK NATATORIUM

UNIVERSITY OF LOUISVILLE

Project: 03006
Drawn: JLR
Checked: M.L.
Scale: AS NOTED
Issue Date: AUGUST 27, 2003
Revision:

FRAMING SECTIONS

S5.02
OFFICIAL BID DOCUMENT