

1 ISLAND - 1 (PG 355)
A10.28 1/2"=1'-0"

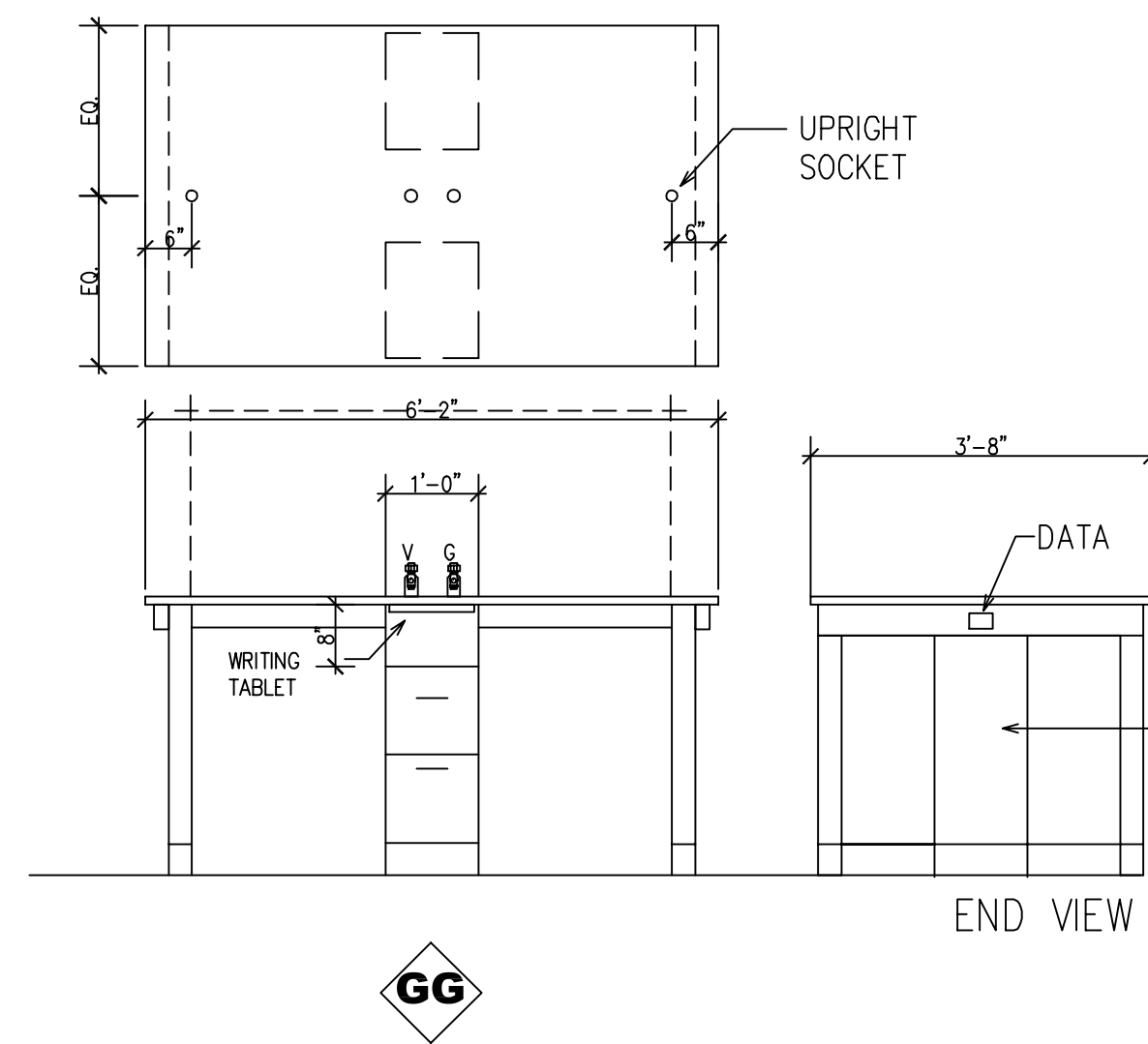

2 ISLAND - 2 (SH 310)
A10.28 1/2"=1'-0"

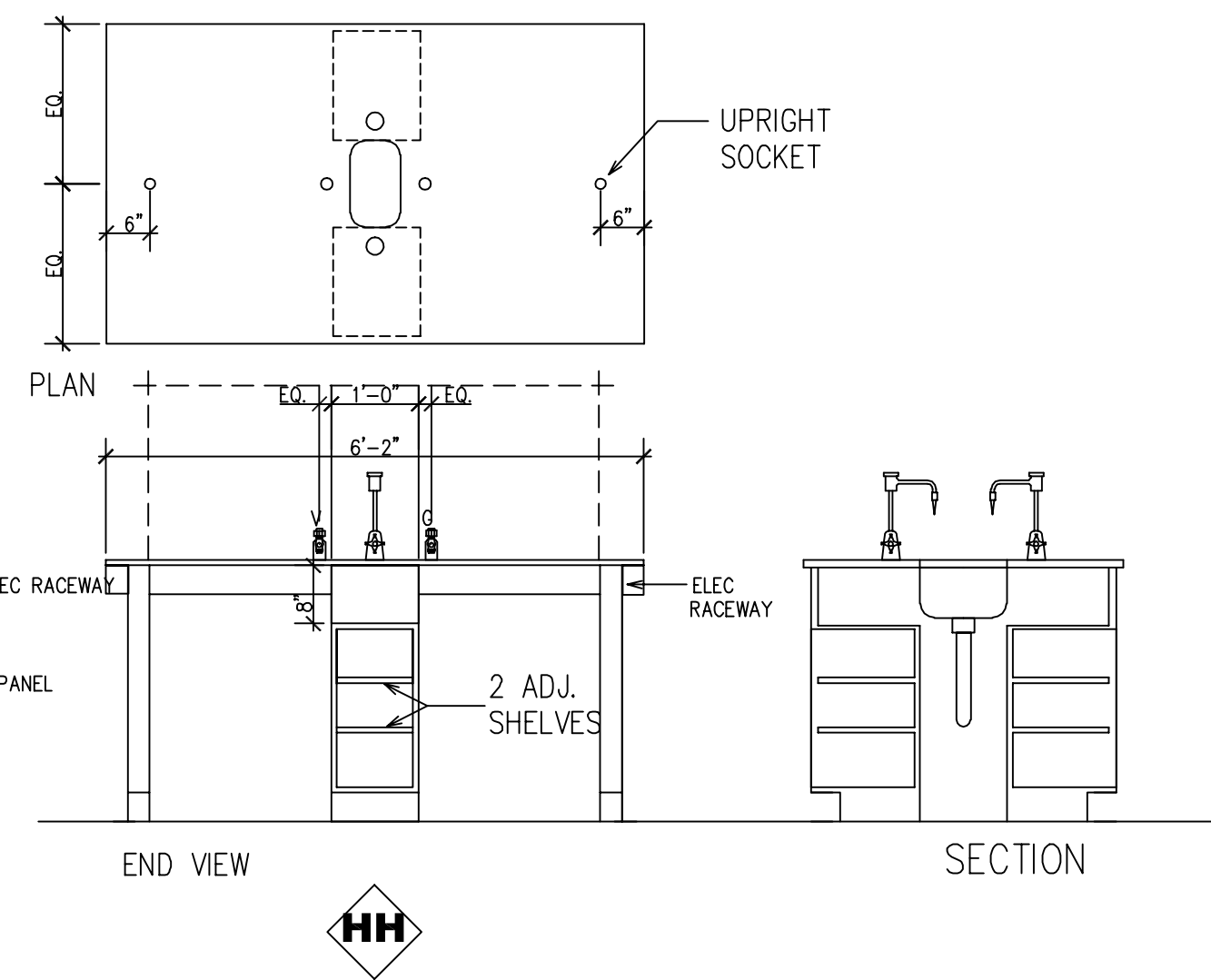

3 ISLAND - 3 (BY360-361)
A10.28 1/2"=1'-0"

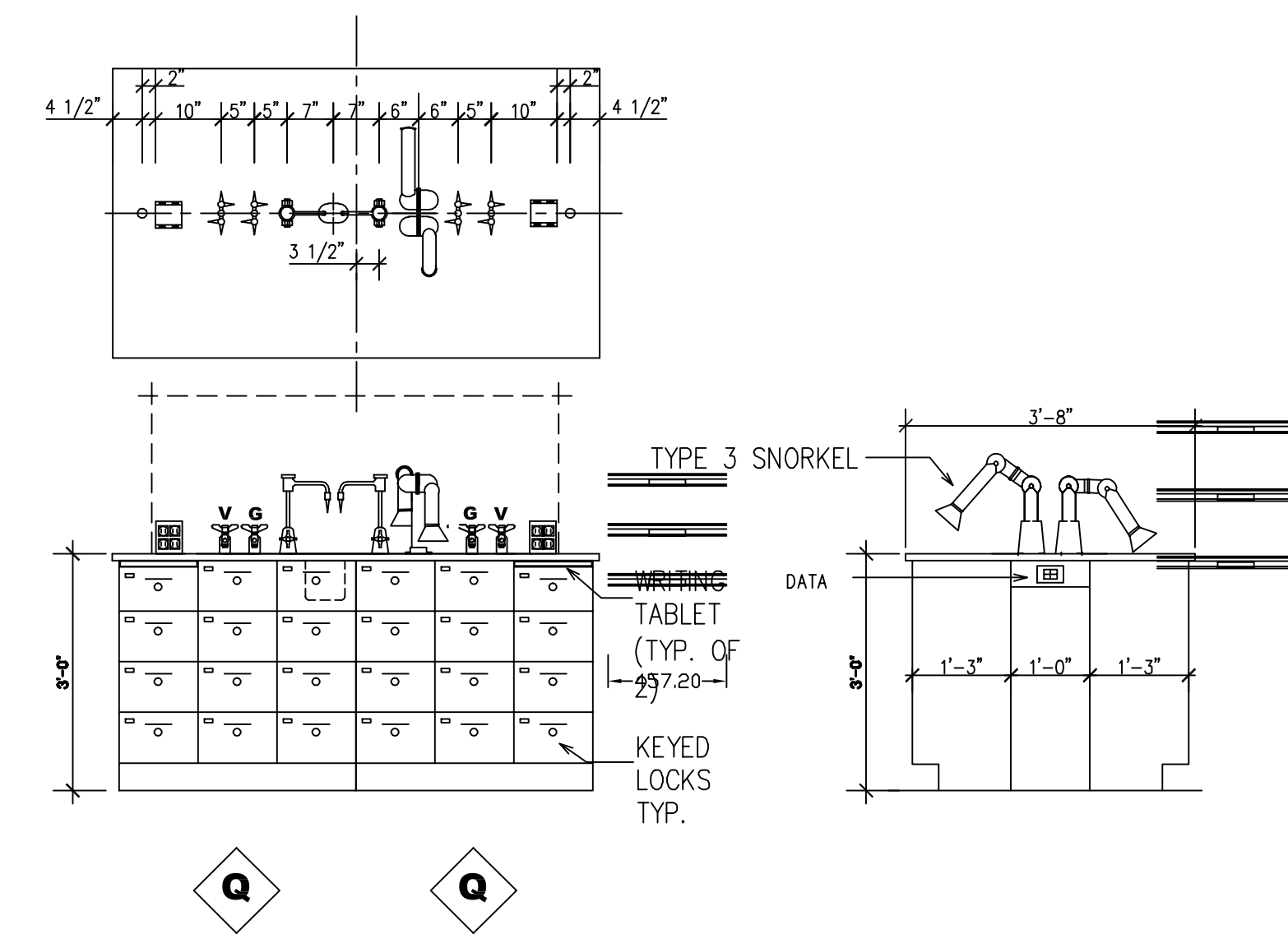

4 ISLAND - 4 (CH260-264)
A10.28 1/2"=1'-0"

ISLAND - 5
1/2"=1'-0"

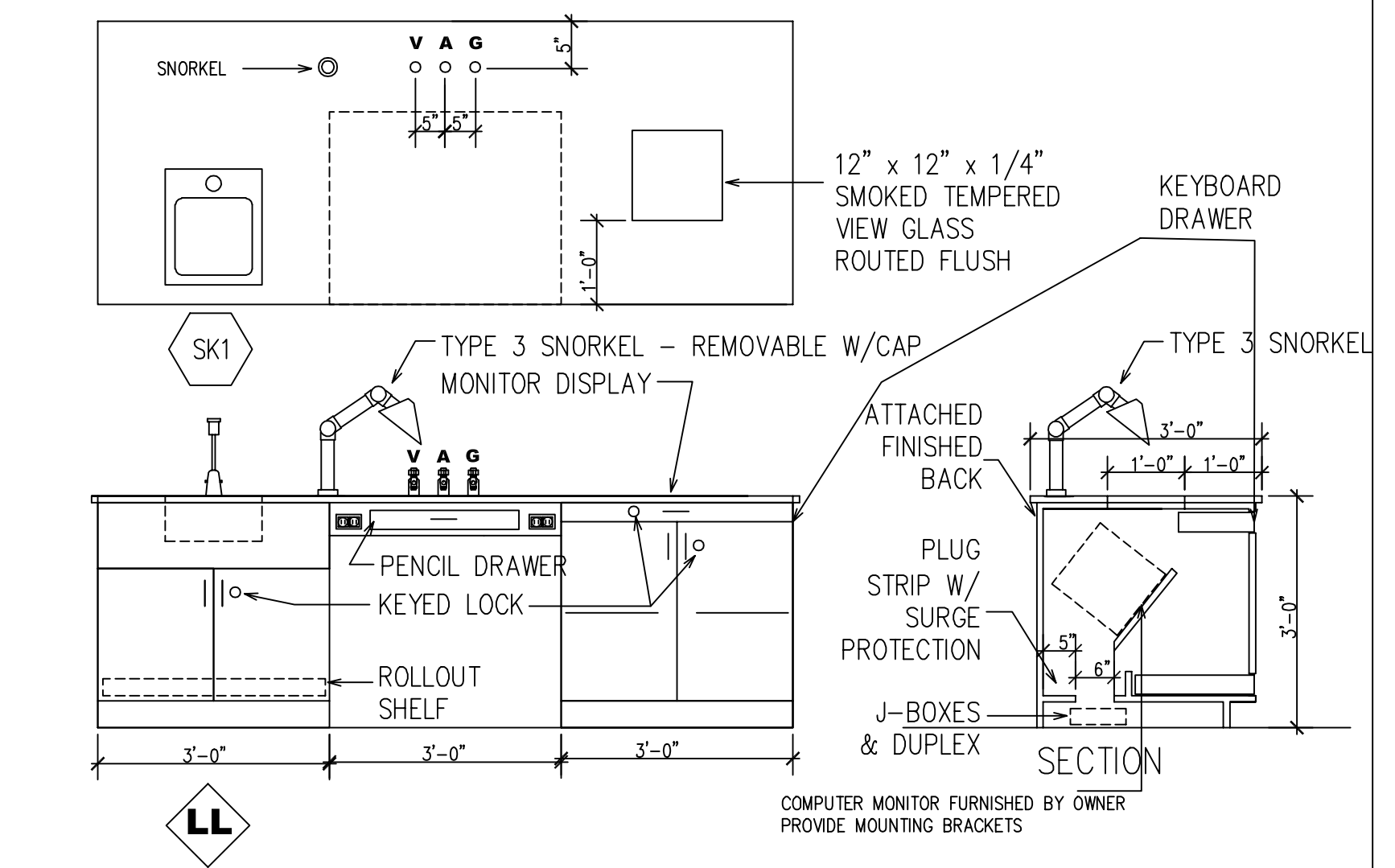

5 LECTURE BENCH
A10.28 1/2"=1'-0"
NOTE: PROVIDE LECTURE BENCH AT BY610, BY620, BY621, CH360, CH361 SEE PLANS FOR ORIENTATION

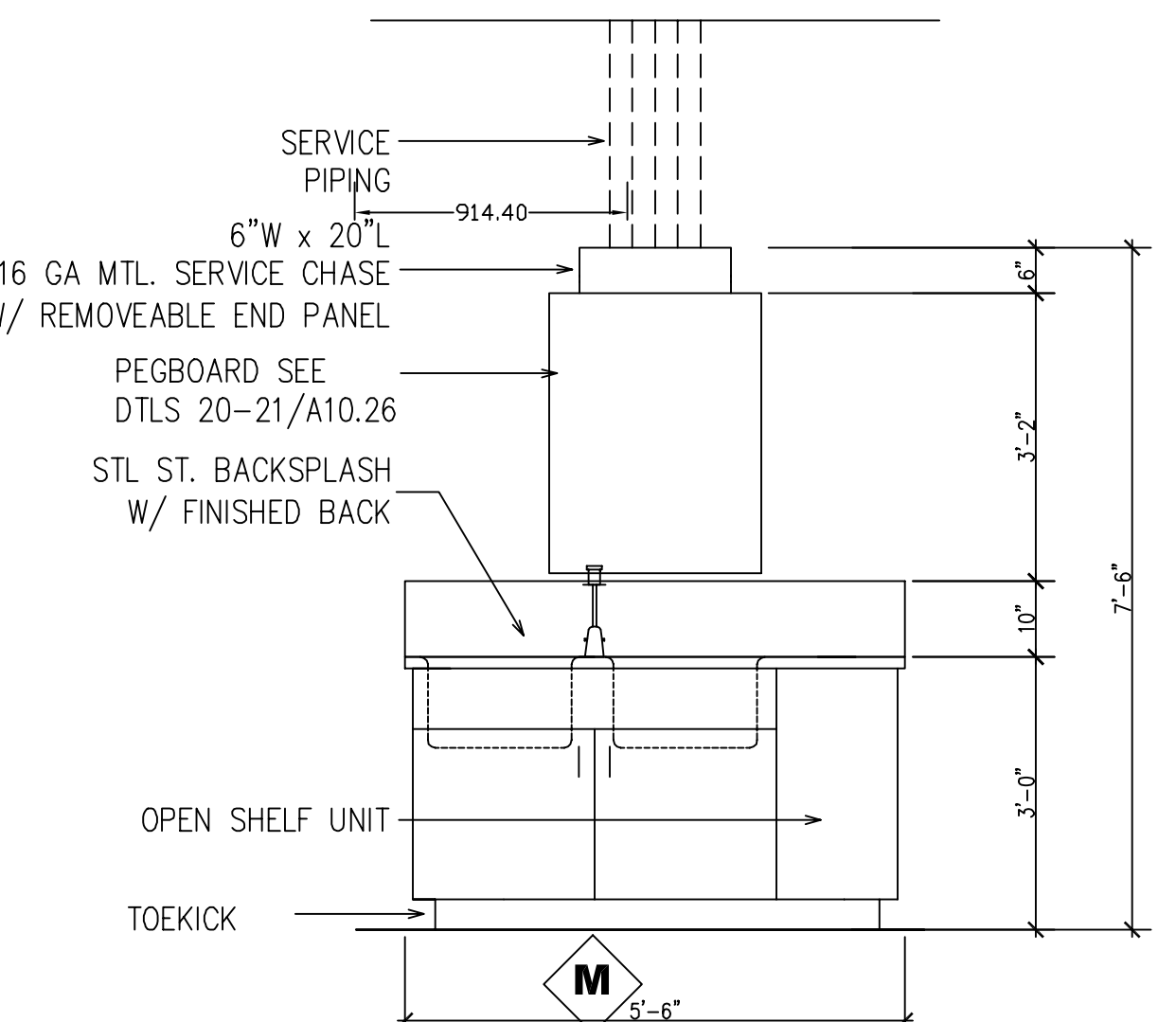

6 END VIEW - RESEARCH ISLAND
A10.28 1/2"=1'-0"

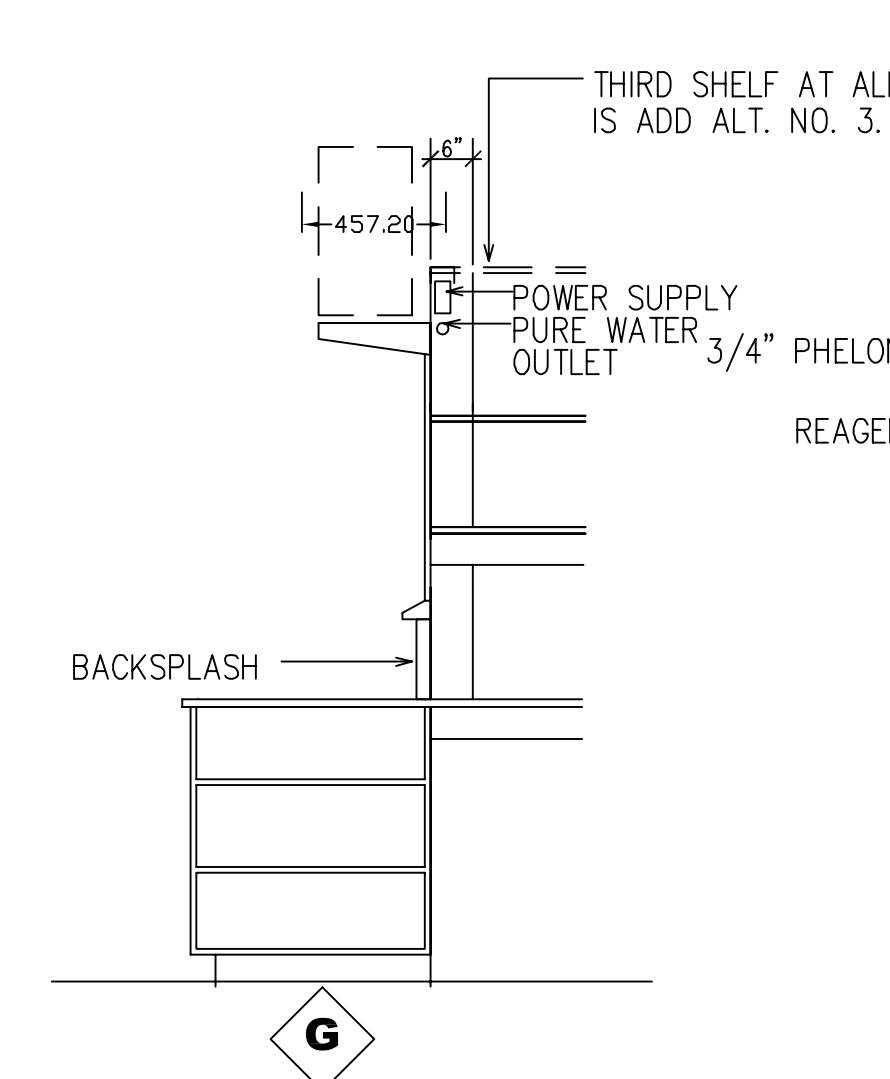

7 SIDE VIEW - RESEARCH ISLAND
A10.28 1/2"=1'-0"

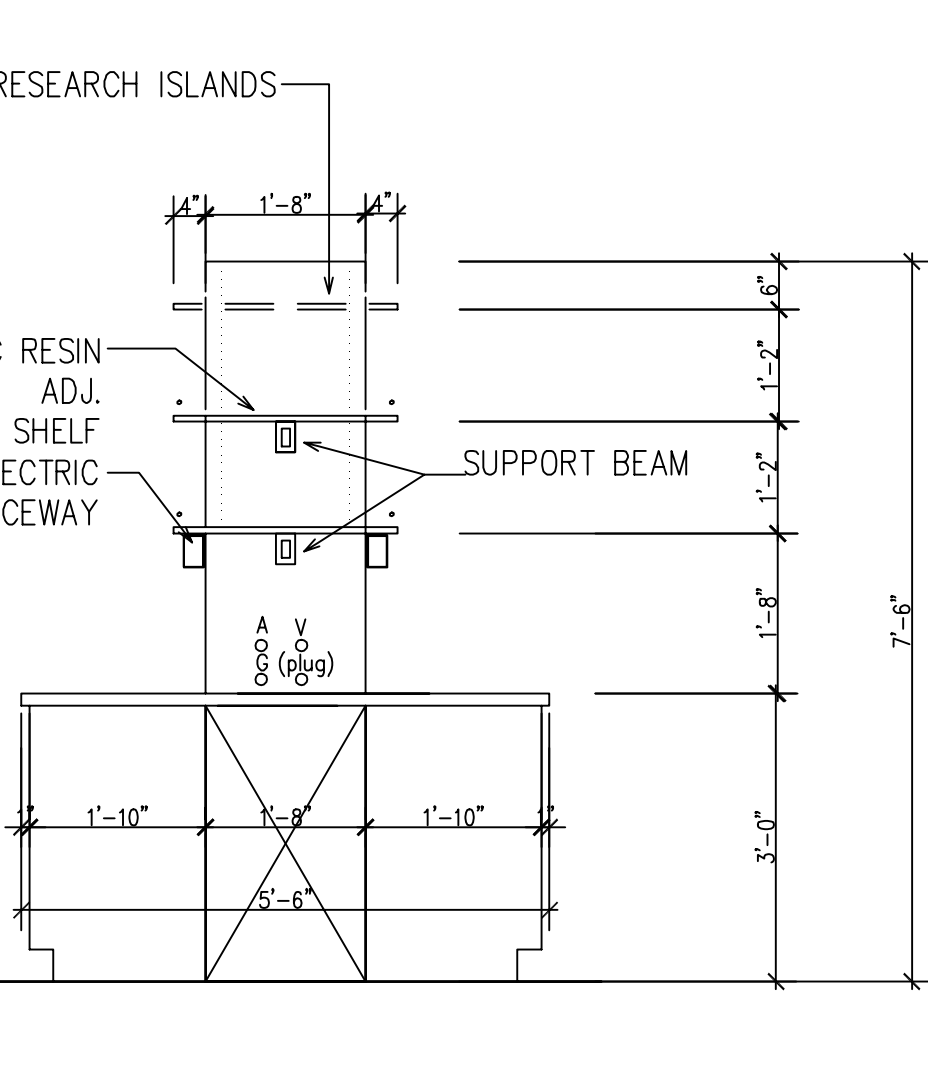

8 ISLAND - SECTION
A10.28 1/2"=1'-0"

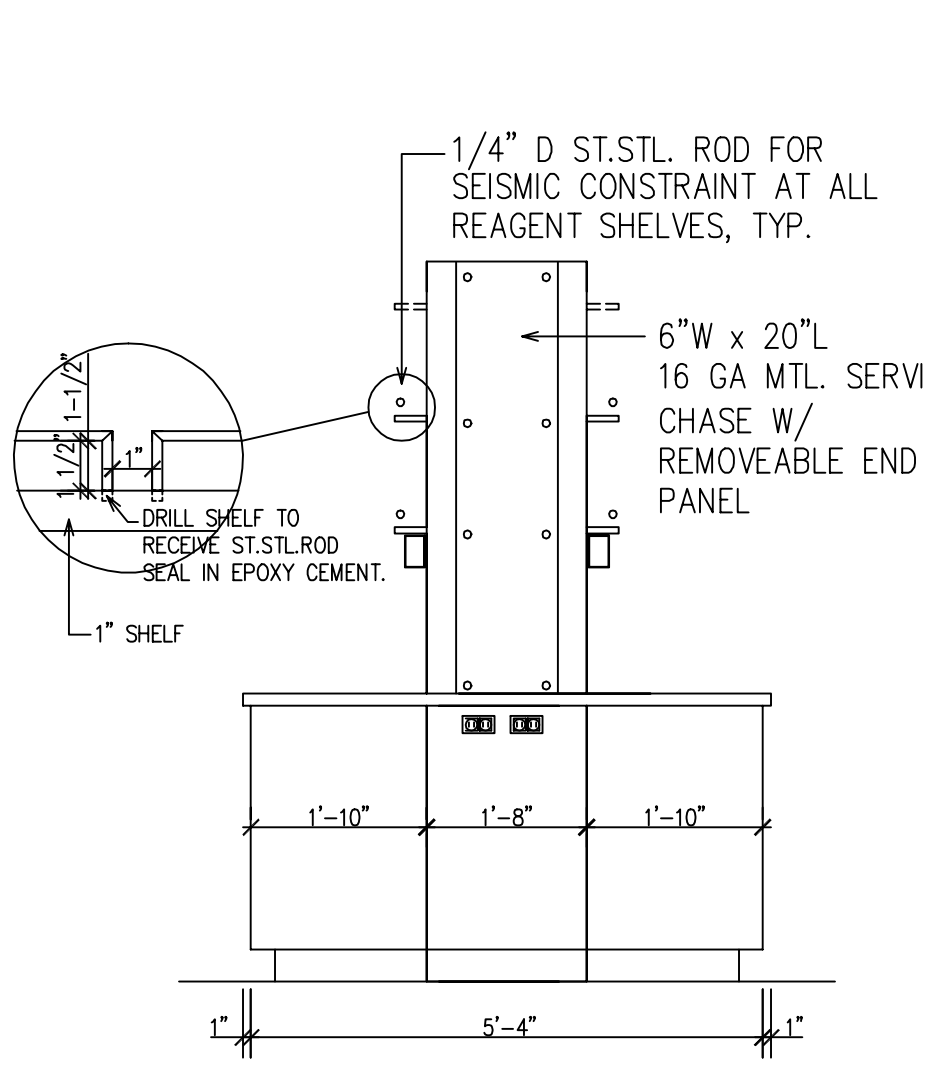

9 ISLAND - END VIEW
A10.28 1/2"=1'-0"

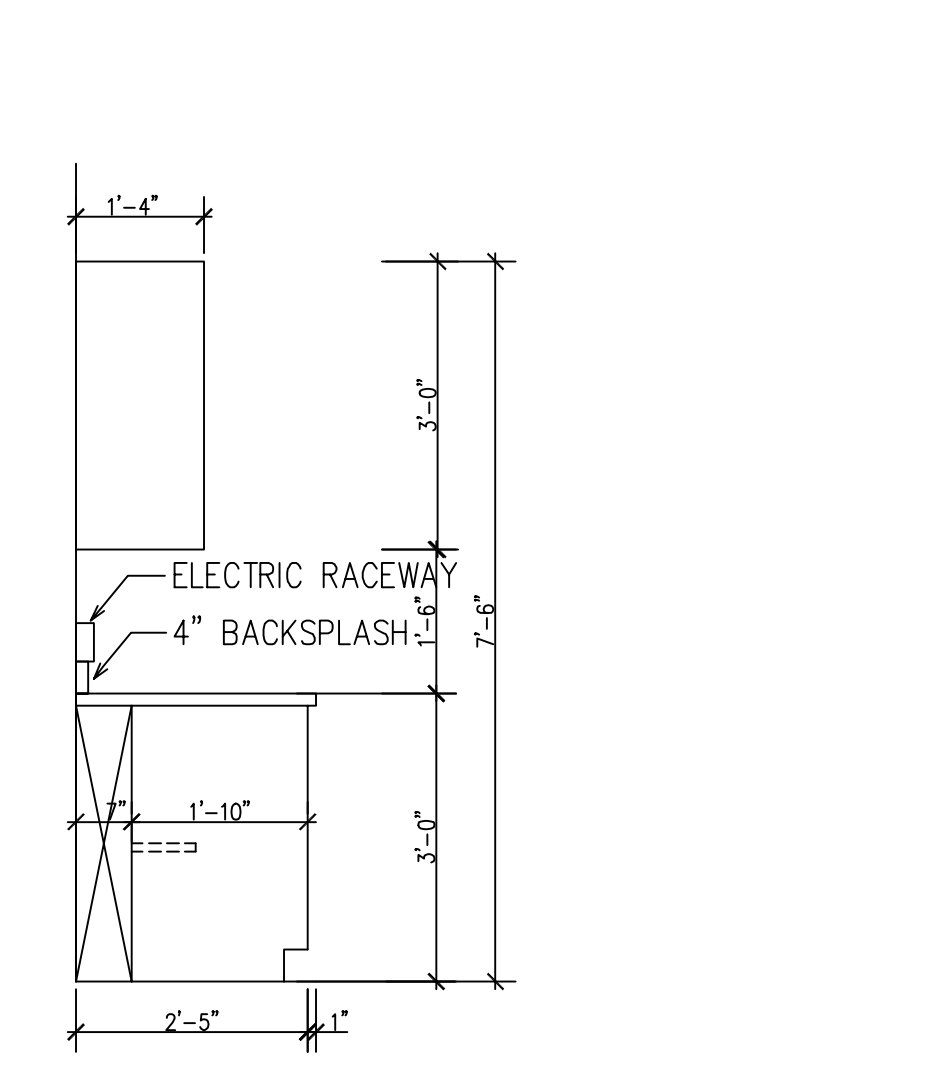

10 TYP. 36\"/>

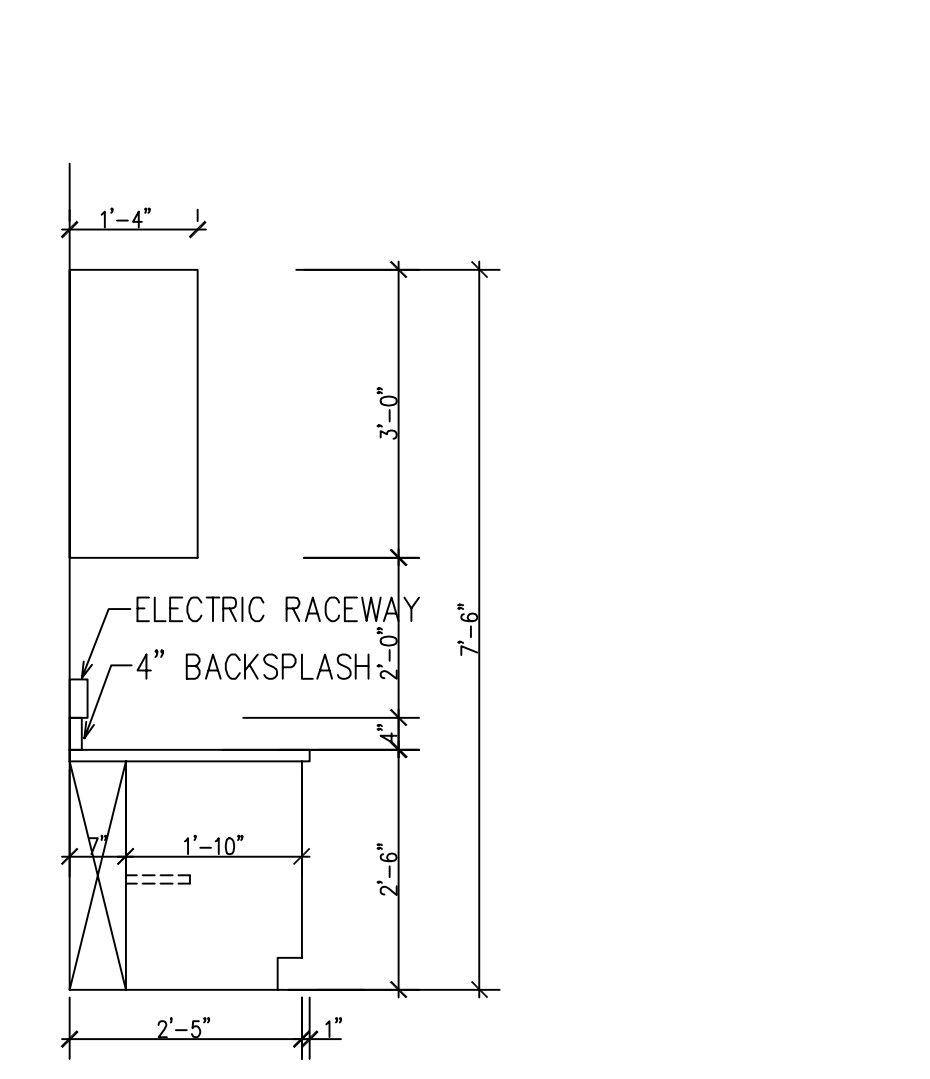

11 TYP. 30\"/>

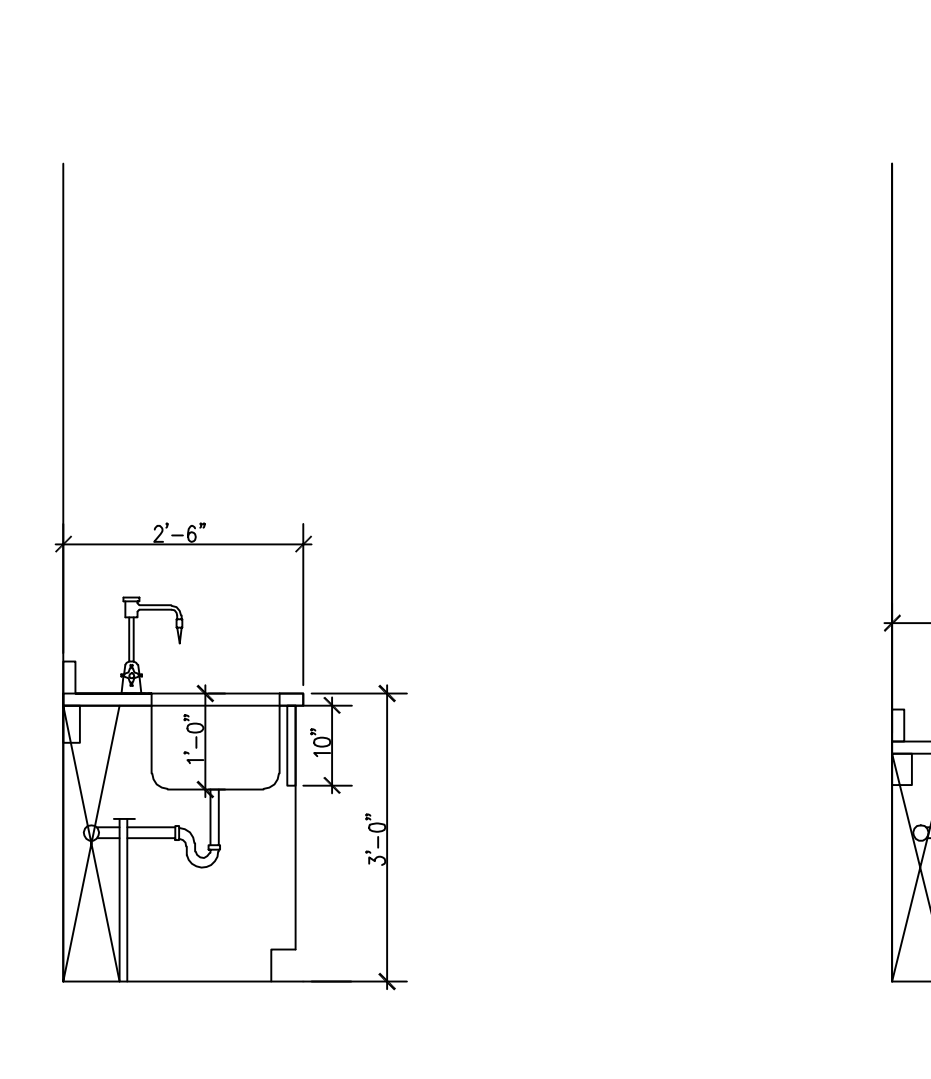

12 36\"/>

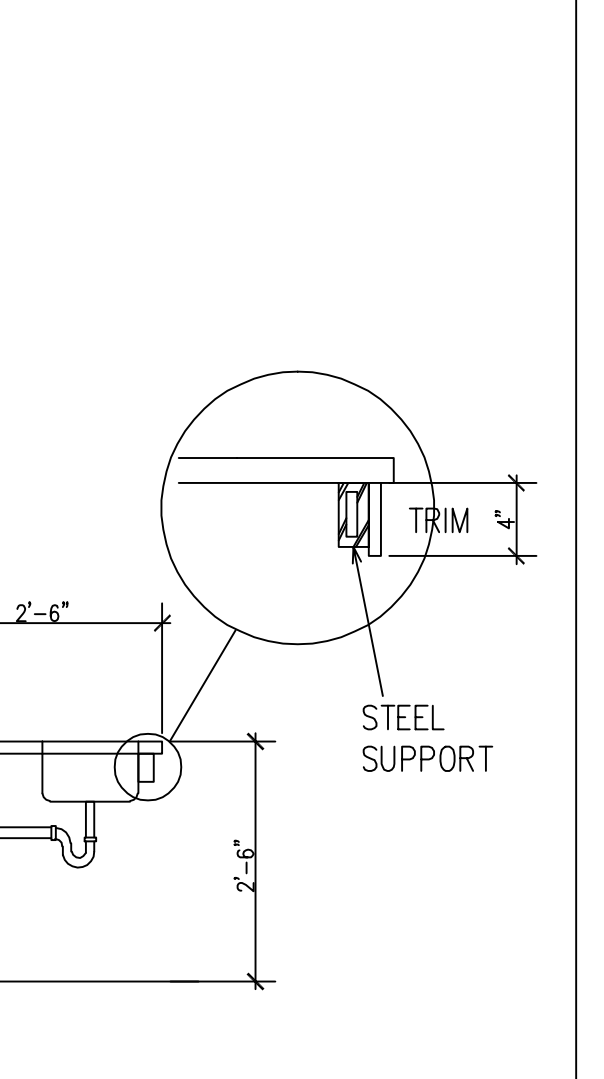

13 30\"/>

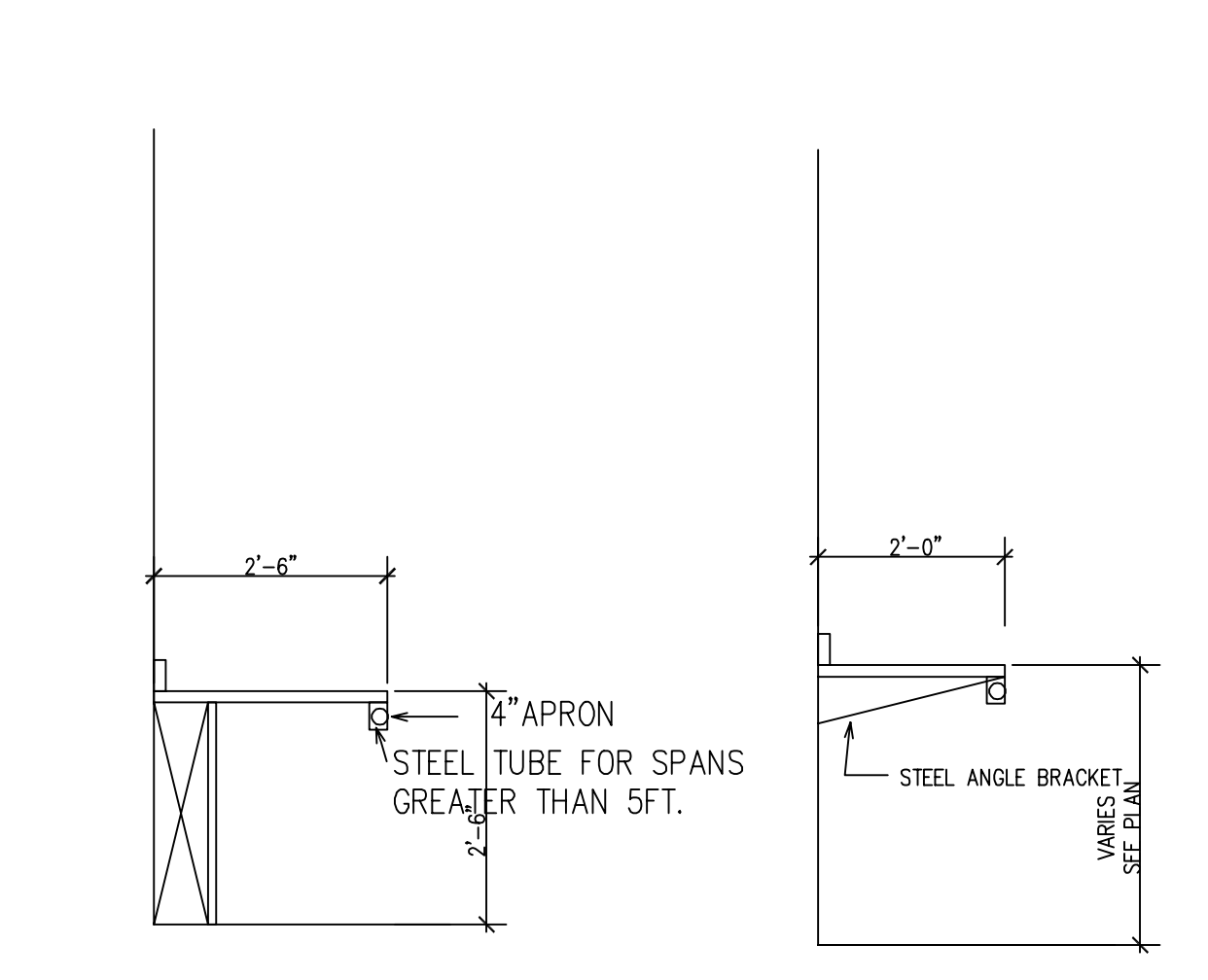

13 30\"/>



14 24\"/>

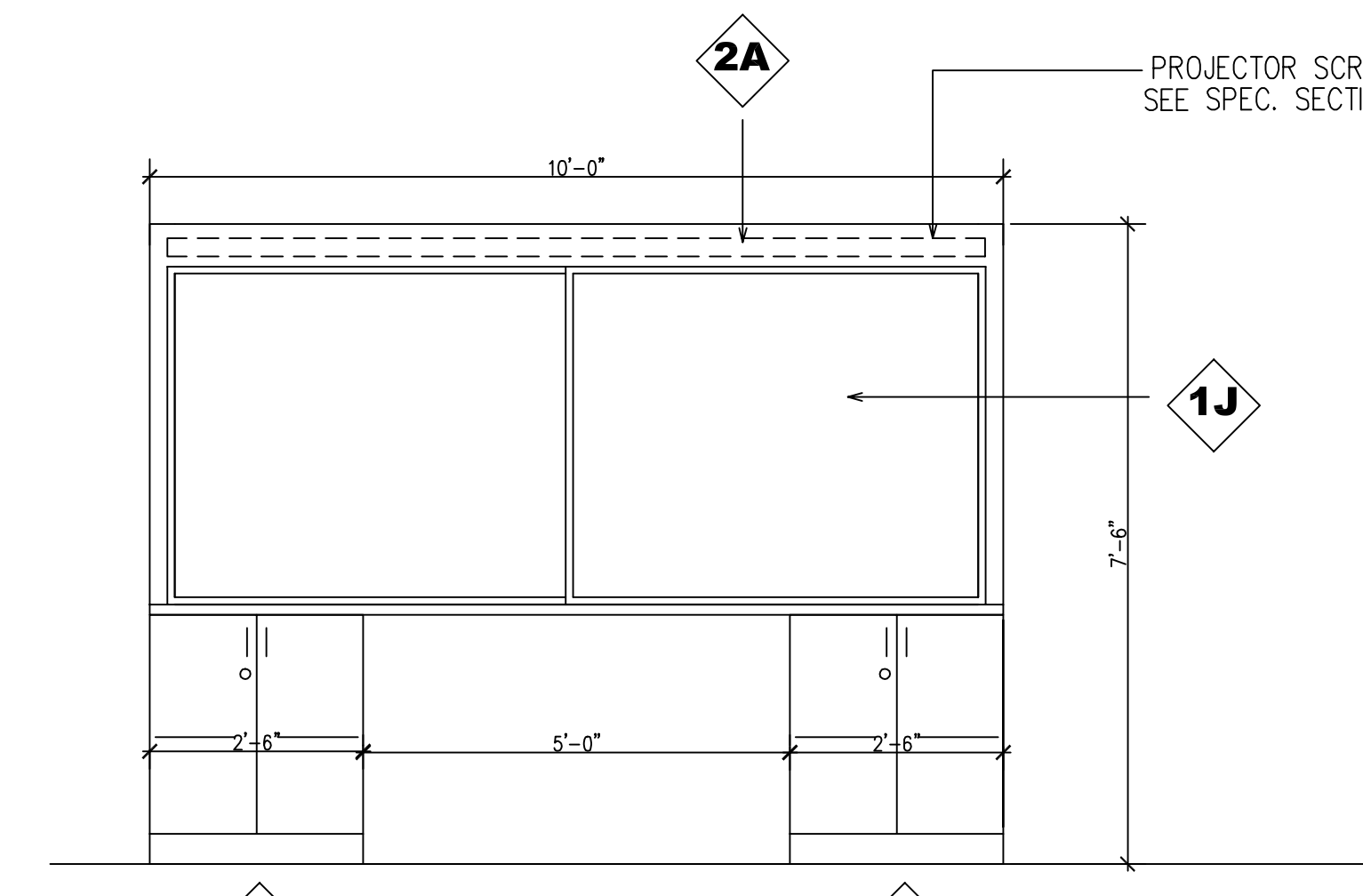

16 8\"/>

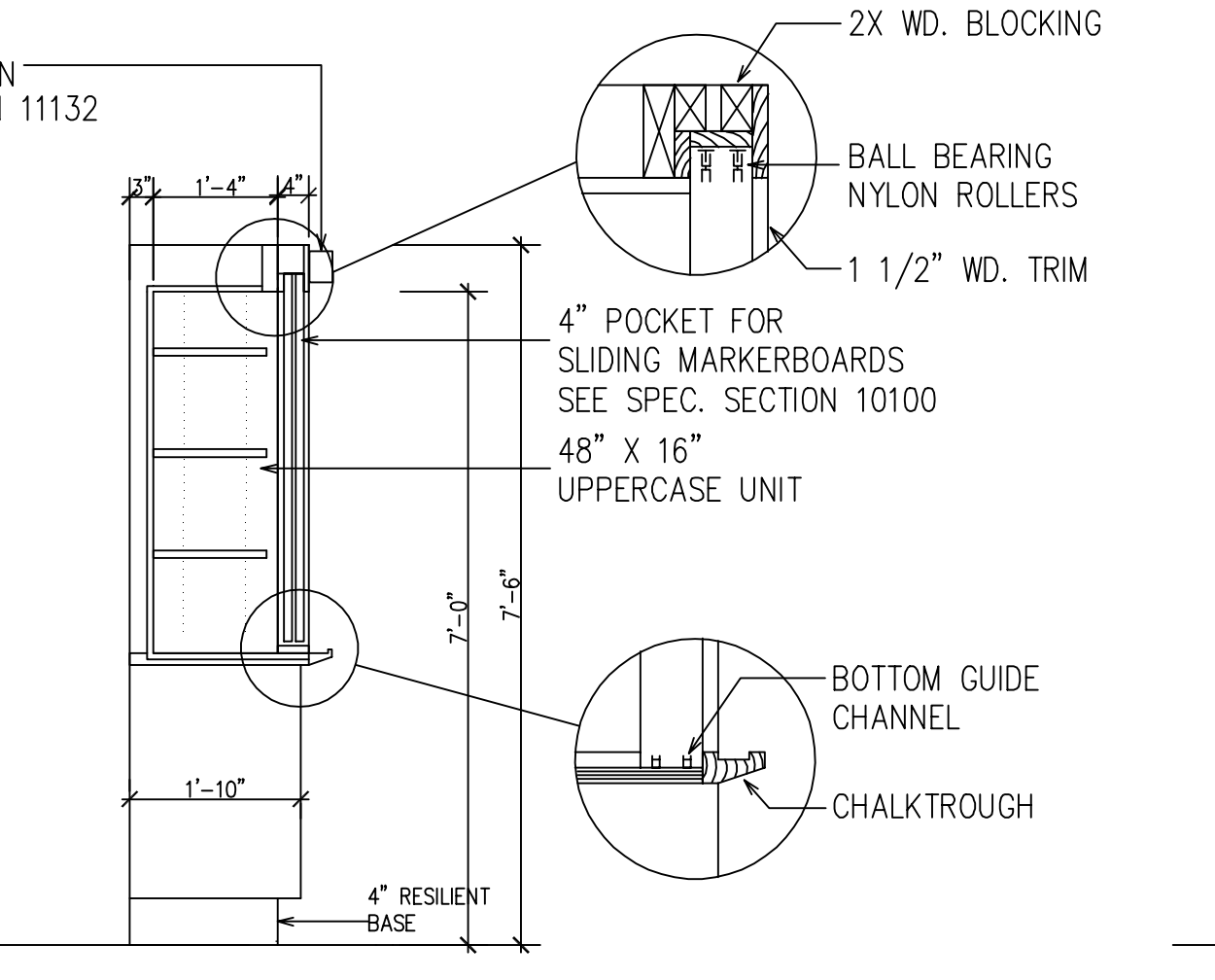

17 SECTION
A10.28 1/2"=1'-0"

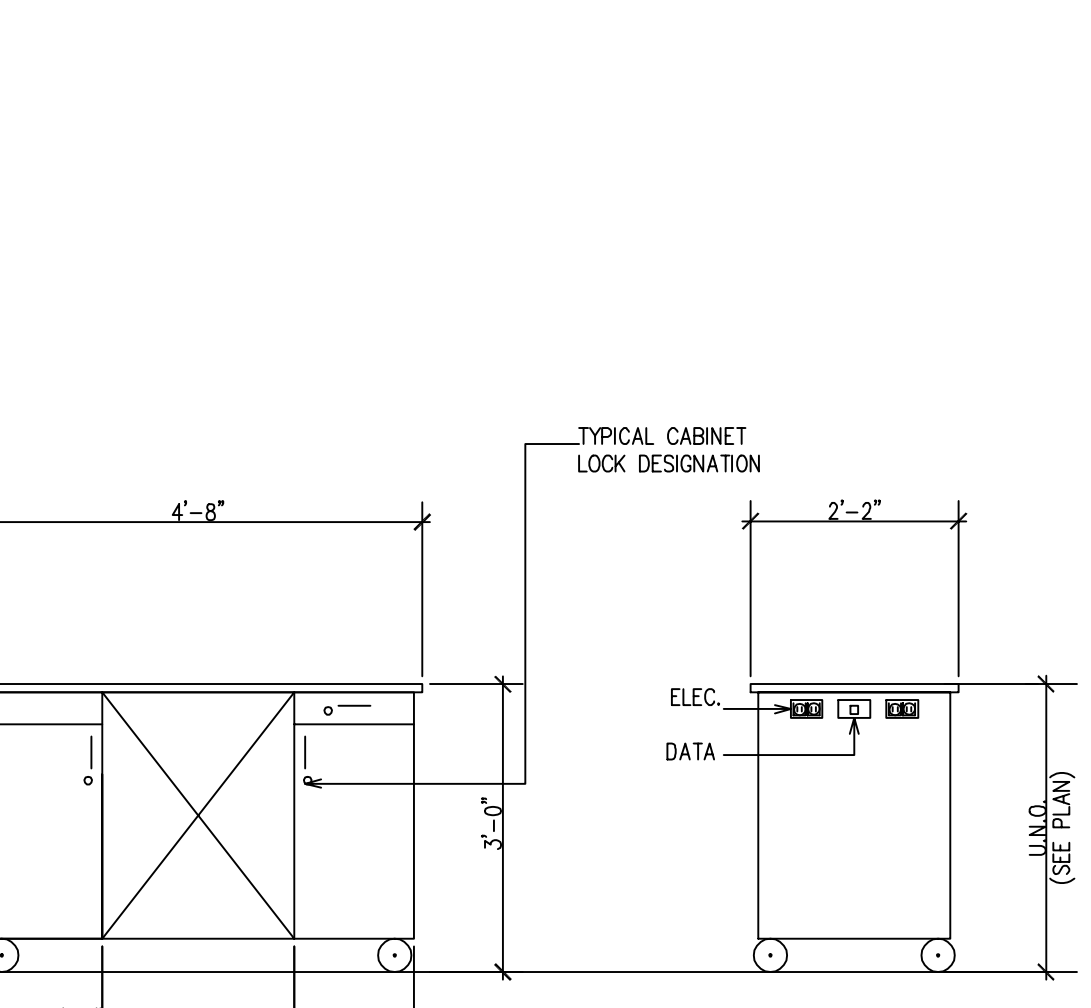

18 DEMONSTRATION CART
A10.28 1/2"=1'-0"

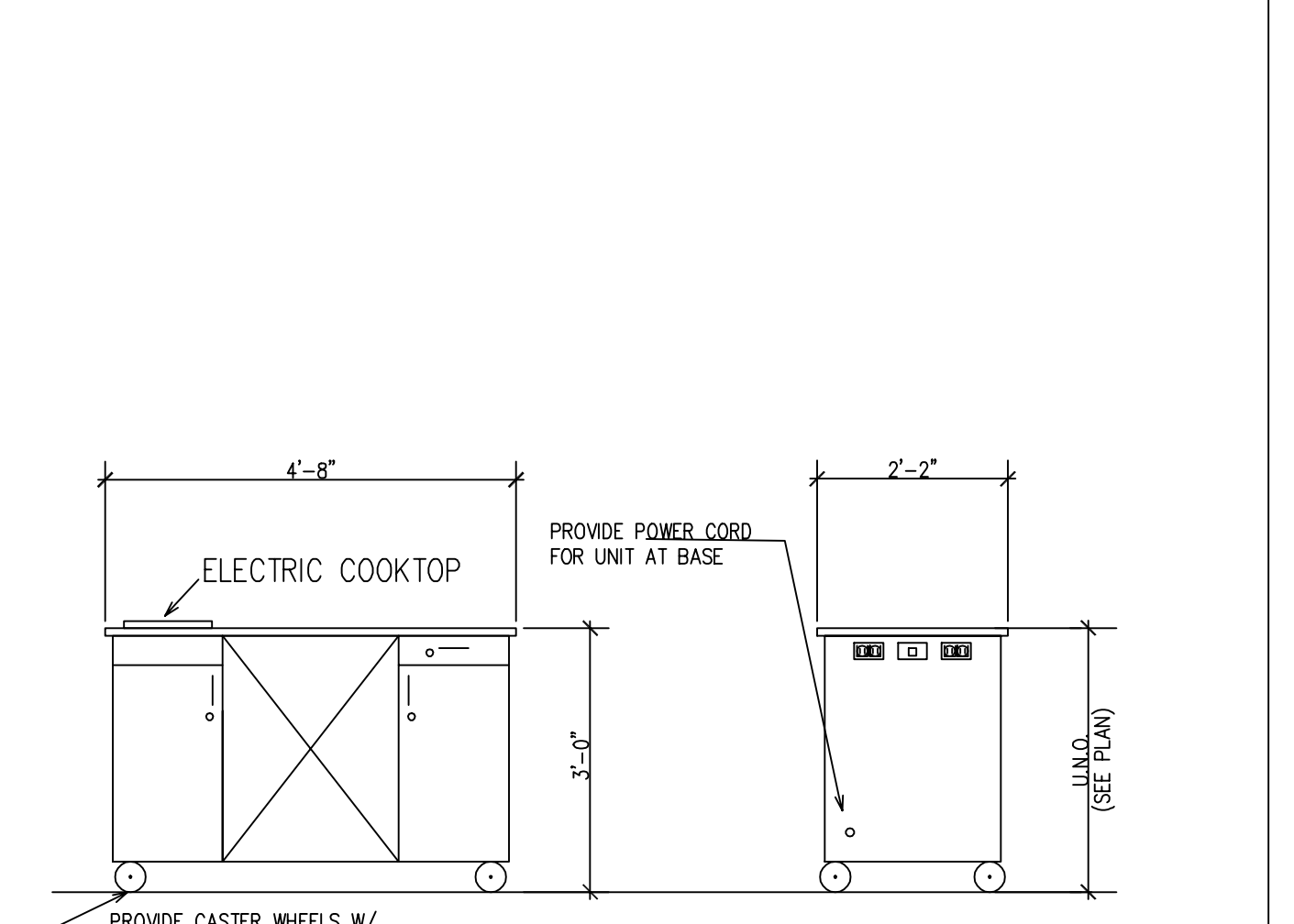

19 MOBILE COOKING STATION
A10.28 1/2"=1'-0"

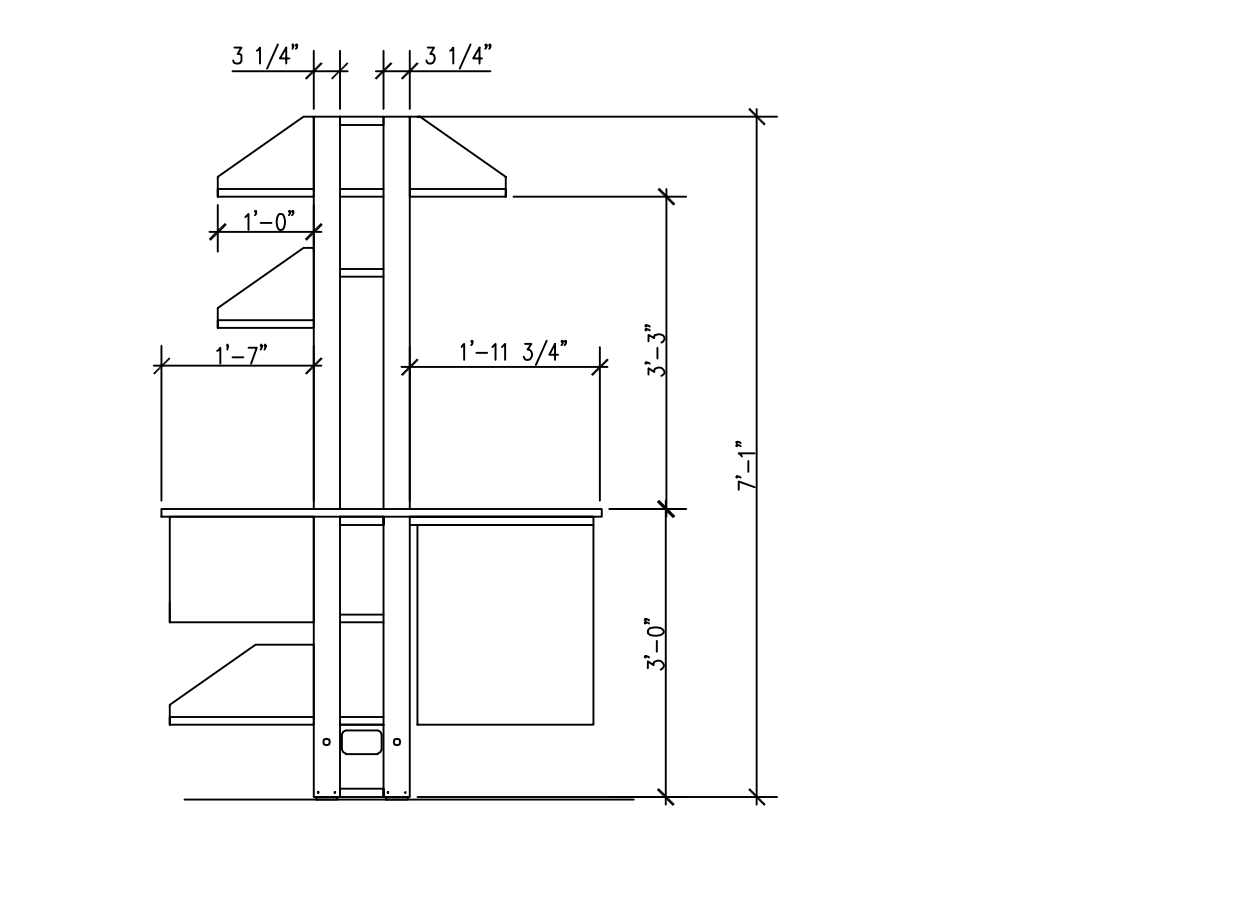

20 (CH345) SECTION
A10.28 1/2"=1'-0"

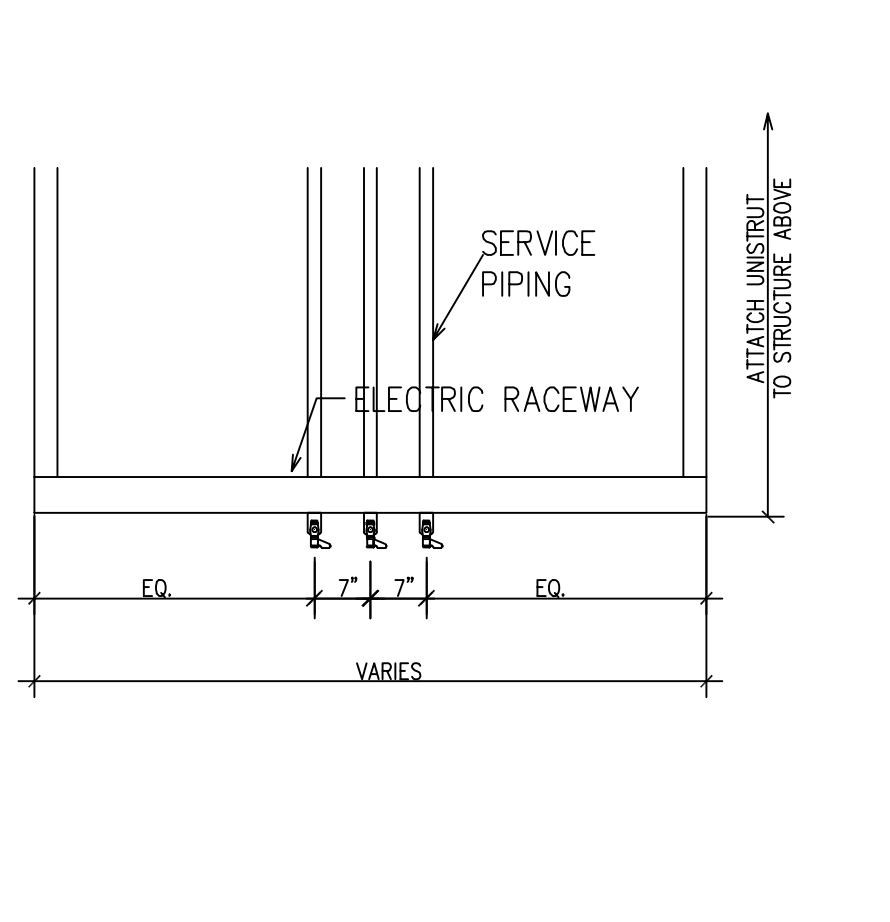

21 OVERHEAD SERVICE SPLINE
A10.28 1/2"=1'-0"

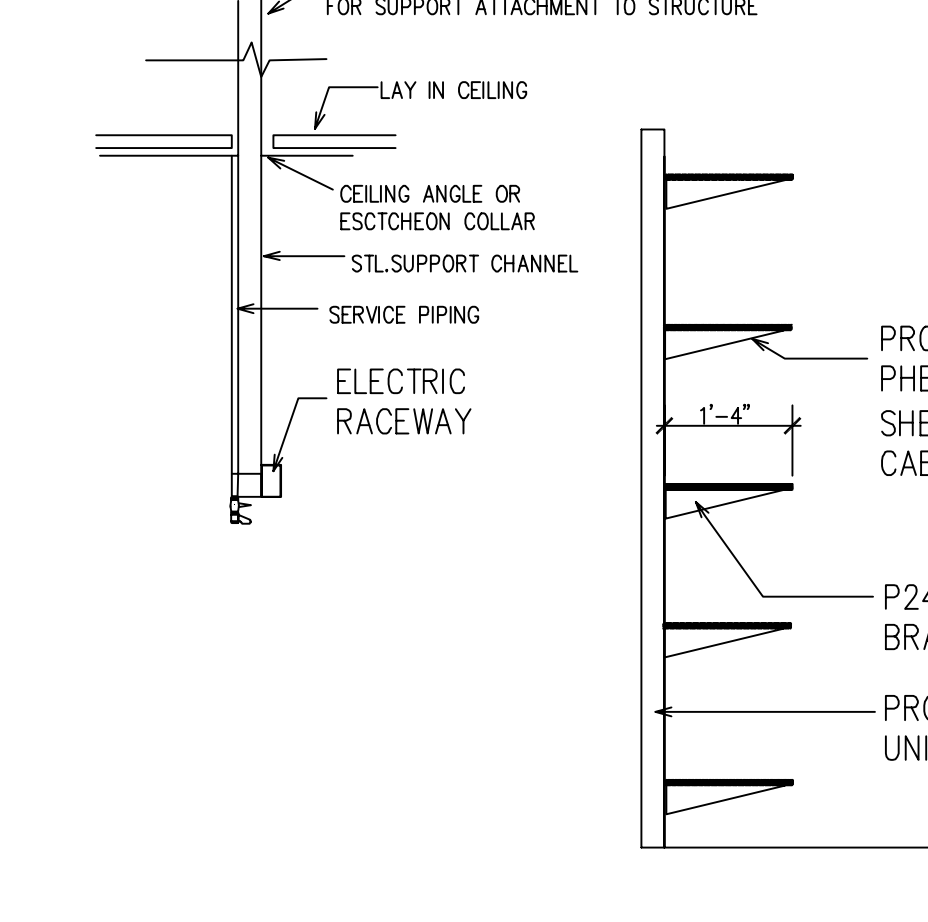

22 SECTION THRU SPLINE
A10.28 1/2"=1'-0"

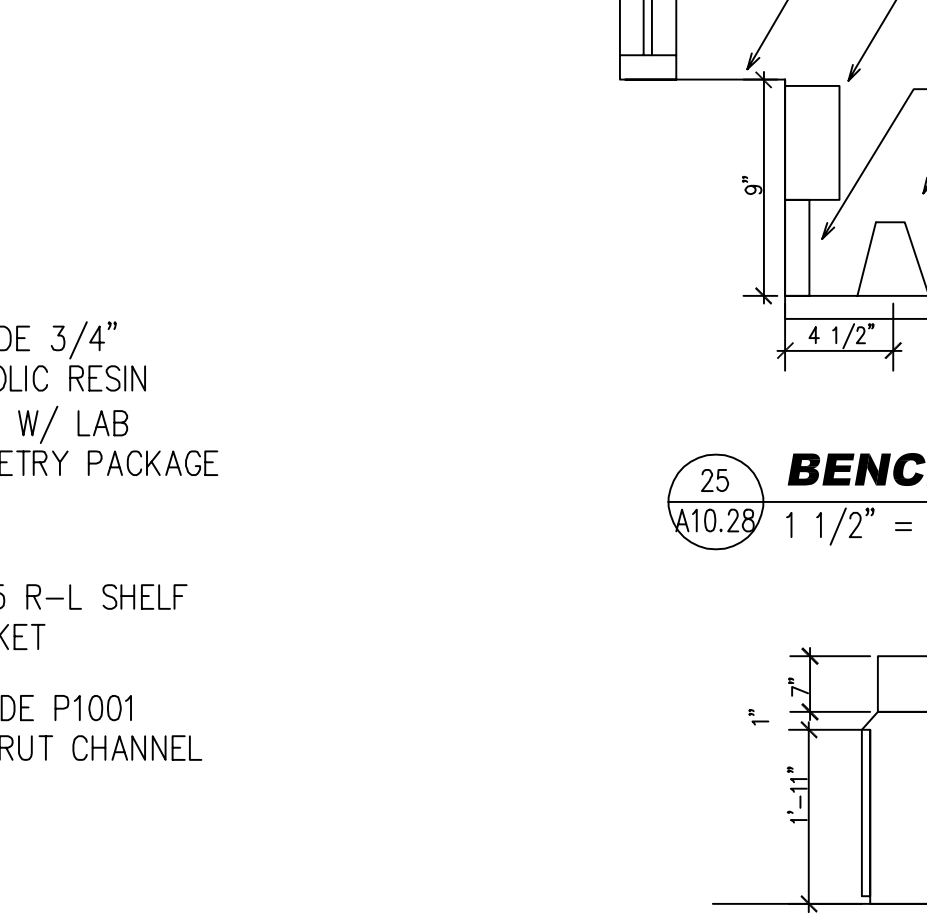

23 ADJUSTABLE WALL SHELF DETAIL
A10.28 1/2"=1'-0"

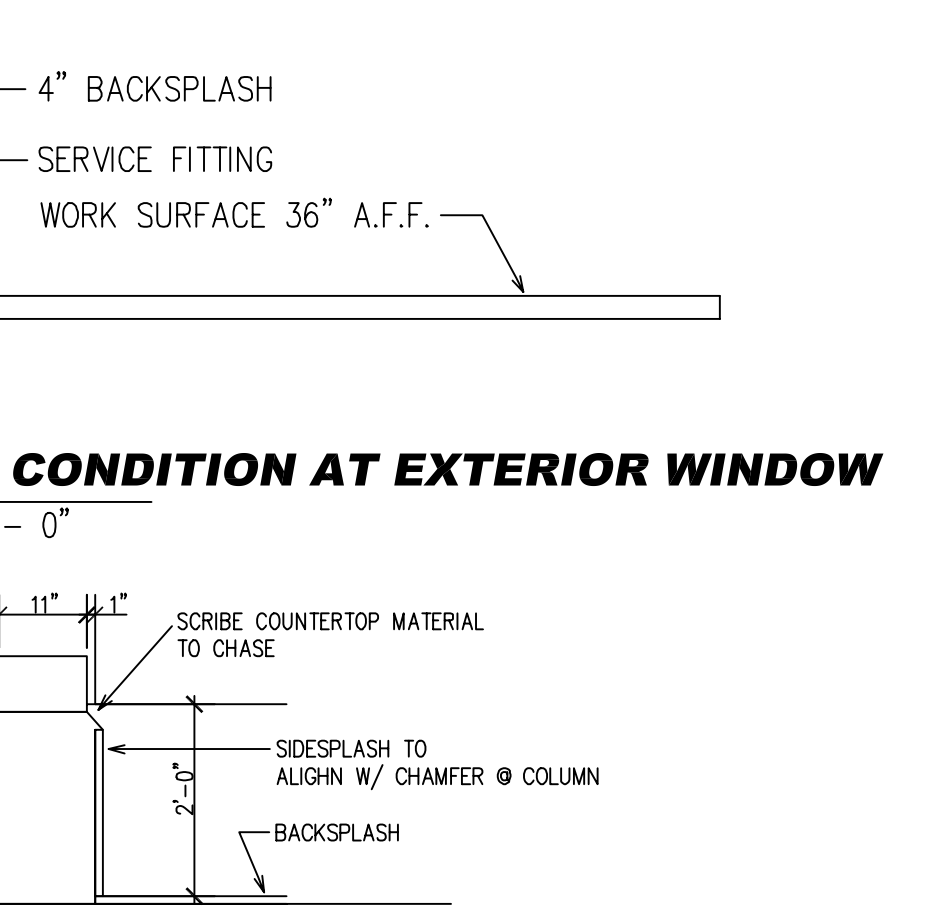

24 COLUMN DETAIL
A10.28 1/2"=1'-0"

01-14-03

LABORATORY DETAILS
A-10.28

REVISIONS		DATE	NORTHERN KENTUCKY UNIVERSITY NATURAL SCIENCE BUILDING		PHASE C
1					
2					
3					
4					
5					
6					
7					
8					
9					

DRAWN BY SAWJEL/JWR CHECKED BY SCH	COMMONWEALTH OF KENTUCKY FINANCE AND ADMINISTRATION CABINET DIVISION OF ENGINEERING DEPARTMENT FOR FACILITIES MANAGEMENT FRANKFORT, KENTUCKY	A-10.28
DATE 6/99		REVIEWED DIV. OF ENGR.
AGENCY AUTHORIZED AGENT DIVISION OF ENGINEERING	APPROVED FOR PROGRAM CONCEPT ONLY	DATE
	APPROVED FOR PROGRAM CONCEPT ONLY	DATE

health education + research associates
hera