



BMK2.0LN GWB

TECHNICAL DATA SHEET

Low NOx Benchmark Gas Fired Hot Water Boiler System

The AERCO Benchmark 2.0 Low NOx (BMK2.0LN) Water Boiler is designed for condensing application in any closed loop hydronic system. It delivers 20:1 burner turndown to match energy input directly to fluctuating system loads to yield the highest possible seasonal efficiencies. As illustrated below, the unit's operating efficiency actually increases as the load decreases. It can achieve 99+% efficiency when supplied with 60°F return water while firing at minimum input.

To minimize emissions, the BMK2.0LN is fitted with a low NOx burner whose emissions will consistently measure <20 ppm of NOx corrected to 3% excess oxygen at all firing rates. Certified by the SCAQMD and TCEQ in its class, the fully modulating burner also maintains AERCO standards for energy efficiency, longevity, reliability and construction quality.

The BMK2.0LN can be used singly or in modular arrangements and offers selectable modes of operation. In addition to controlling the boiler according to a constant set point, indoor/outdoor reset schedule or 4-20mA signal, one or more can be integrated via Modbus communications protocol to AERCO's multiple boiler management system (BMS II) or a facility-wide Energy Management or Building Automation System.



THERMAL EFFICIENCY

Comprehensive tests are being conducted to confirm the unit's efficiency over its entire 100,000 to 2,000,000 BTU/hr. operating range for a variety of operating conditions. The initial boundary tests indicate that efficiency up to 99.3% can be achieved when the unit operates at its lowest firing rate (5% input) with 60°F inlet water temperature. Even at full fire (100% input) with 160°F inlet water temperature, the BMK2.0LN delivers 85.3% efficiency.

Thermal Efficiency of BMK2.0LN

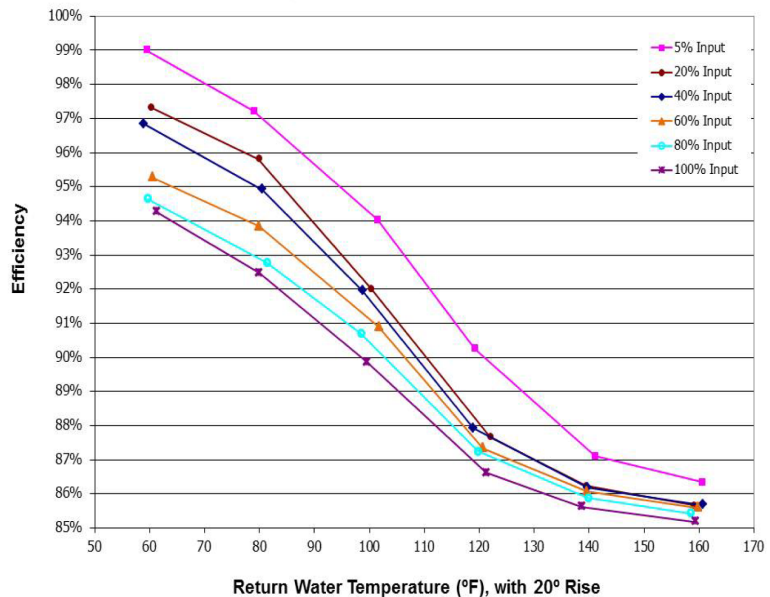

FEATURES:

- Natural Gas
- (Optional) Dual-Fuel – Natural Gas with Propane Back-Up
- Separate Fuel Connections Provided with Dual Fuel Option
- 20:1 Turndown Ratio
- Nox Emissions <20 ppm at All Firing Rates (when fired with natural gas)
- Direct or Conventional Vent Capabilities
- AL29-4C Vent Materials Required per UL1738
- Quiet Operation Throughout Firing Range
- Internal Low Water Cutoff (Manual Reset)
- Compact Footprint (79"H x 28"W x 36"D)
- Precise Temperature Control
- Sealed Combustion Capable
- Ventless Supply Gas Regulator
- UL, CUL, for Alcove Installation on Combustible Flooring

DIMENSIONS:

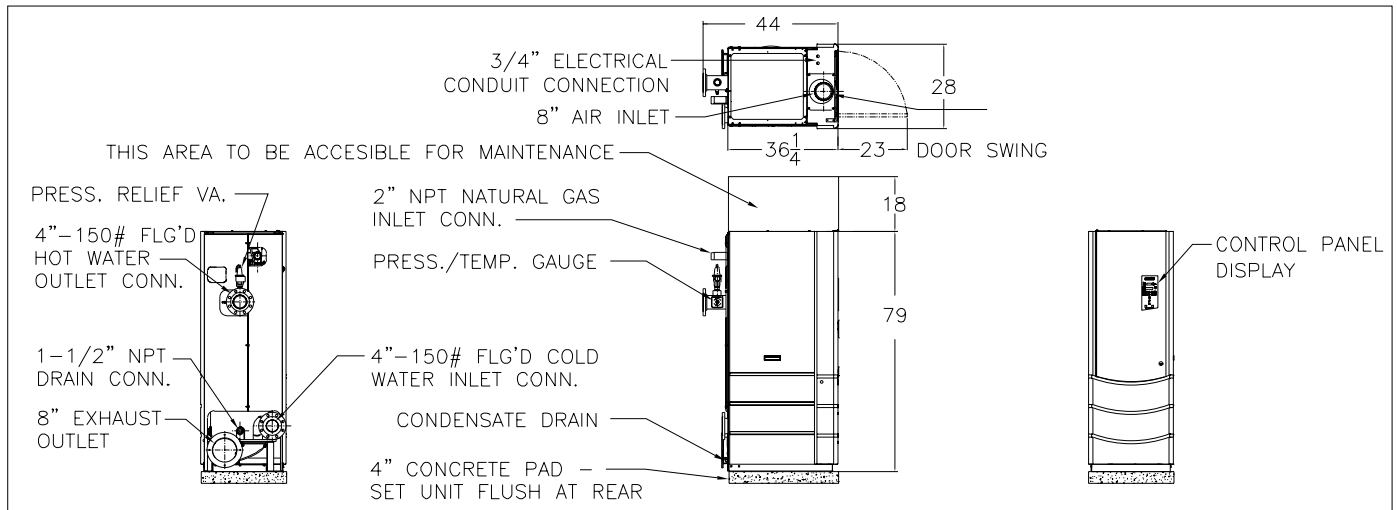

RATINGS AND DIMENSIONS:

Modules	Model (a)	Mbh Input (b)	Mbh Output (b) (c)	Width (1)	Depth	Height	Weight (wet)
One (1)	BMK-2.0LN	2,000mbh	1,706mbh - 1,860mbh	2'4"	3'10"	6'7"	1,650lbs.
Two (2)	BMK-2.0LN-2	4,000mbh	3,412mbh - 3,720mbh	6'8"	3'10"	6'7"	3,330lbs.
Three (3)	BMK-2.0LN-3	6,000mbh	5,118mbh - 5,580mbh	11'0"	3'10"	6'7"	4,950lbs.
Four (4)	BMK-2.0LN-4	8,000mbh	6,824mbh - 7,440mbh	15'4"	3'10"	6'7"	6,600lbs.
Five (5)	BMK-2.0LN-5	10,000mbh	8,530mbh - 9,300mbh	19'8"	3'10"	6'7"	8,250lbs.
Six (6)	BMK-2.0LN-6	12,000mbh	10,236mbh - 11,160mbh	24'0"	3'10"	6'7"	9,900lbs.
Seven (7)	BMK-2.0LN-7	14,000mbh	11,942mbh - 13,020mbh	28'4"	3'10"	6'7"	11,550lbs.
Eight (8)	BMK-2.0LN-8	16,000mbh	13,648mbh - 14,880mbh	32'8"	3'10"	6'7"	20,640lbs.

(1) Assume 24" between units. Zero side wall clearance is not provided. Consult local sales representative.

(a) Style to be determined by individual application requirement.

(b) Altitude below 2000'. Apply altitude correction factor above 2000'.

(c) Output dependent upon application - see efficiency curves

SPECIFICATIONS:

BTU Input.....2,000,000 BTU/H*
Min. Output @ Full Input.....1,706,000-1,860,000 BTU/H**
ASME Working Pressure.....160 PSIG
Electrical Options.....120/1/60 20 Amo (15.0 Amp FLA)
Gas Requirements.....14" W.C Maximum
Standard Unit-FM Gas Train.....4.0" W.C. Min. @ Full Load
Standard Unit-IRI Gas Train.....5.0" W.C. Min. @ Full Load
Dual Fuel-FM Gas Train-Nat. Gas.....8.5" W.C. Min. @ Full Load
Dual Fuel-FM Gas Train-Propane.....8.5 W.C. Min. @ Full Load
Dual Fuel-IRI Gas Train-Nat. Gas.....9.5" W.C. Min. @ Full Load
Dual Fuel-IRI Gas Train-Propane.....9.5" W.C. Min. @ Full Load
Vent Size.....8" Diameter

Water Connections.....4" Flanged 150lb. ANSI
Gas Connection.....2" NPT
Min./Max. Water Flow.....25 GPM / 350 GPM***
Water Pressure Drop.....1.7 PSIG @ 170 GPM
Water Volume.....24 gallons
Control Range.....50°F to 190°F
Ambient Temperature.....0°F to 130°F
NOx Emissions Certification.....SCAQMD, TCEQ
Standard Listings & Approvals.....UL, CUL, CSD-1, ASME
Gas Train Options.....FM Compliant or Factory Installed IRI
Weight, Installed.....1,450 lbs. (dry), 1650 lbs. (wet)

*Up to 2000' Altitude

**Output is dependent upon return water temp. and firing rate.

Represented By:



WATER HEATERS • BOILERS • PARTS & ACCESSORIES
AERCO INTERNATIONAL, INC.
100 ORITANI DR. • BLAUVELT, NY 10913
(845) 580-8000 • FAX (845) 580-8090
www.aerco.com

Specifications subject to change without prior notice.
Consult website or contact AERCO.
BMK2.0LN 01/2012 NY